

C30902 and C30921 Series

High-speed solid state detectors for low light level applications

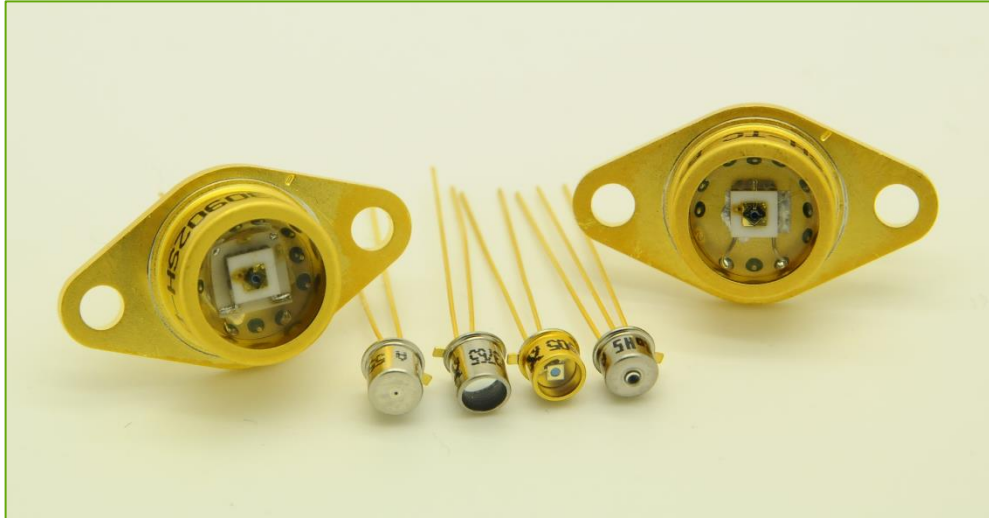

The C30902EH series of avalanche photodiodes is ideal for a wide range of applications, including LIDAR, range-finding, small-signal fluorescence, photon counting and bar code scanning.

Excelitas Technologies' C30902EH series of avalanche photodiodes is fabricated with a double-diffused "reach-through" structure. This structure provides high responsivity between 400 and 1000 nm as well as extremely fast rise and fall times at all wavelengths. The responsivity of the device is independent of modulation frequency up to about 800 MHz. The detector chip is hermetically-sealed behind a flat glass window in a modified TO-18 package. The useful diameter of the photosensitive surface is 0.5 mm.

The C30921EH is packaged in a lightpipe TO-18 which allows efficient coupling of light to the detector from either a focused spot or an optical fiber up to 0.25 mm in diameter. The hermetically-sealed TO-18 package allows fibers to be mated to the end of the lightpipe to minimize signal losses without fear of endangering detector stability. The C30902EH-2 or C30902SH-2, with hermetic TO-18 package with inline 905nm passband filter and the C30902BH, with hermetic ball lens, complete the C30902 family.

Both C30902SH and C30921SH are selected C30902EH and C30921EH photodiodes having extremely low noise and bulk dark-current. They are intended for ultra-low light level applications (optical power less than 1 pW) and can be used in either their normal linear mode ($V_r < V_{br}$) at gains up to 250 or greater, or as photon counters in the "Geiger" mode ($V_r > V_{br}$) where a single photoelectron may trigger an avalanche pulse of about 10^8 carriers. In this mode, no amplifiers are necessary and single-photon detection probabilities of up to approximately 50% are possible.

Photon-counting is also advantageous where gating and coincidence techniques are employed for signal retrieval.

www.excelitas.com

Key Features

- High quantum efficiency: 77% typical at 830 nm
- C30902SH and C30921SH can be operated in Geiger mode
- C30902EH/SH-2 version with built-in 905 nm filter
- C30902BH version with ball-lens
- Hermetically sealed package
- Low Noise at room temperature
- High responsivity – internal avalanche gains in excess of 150
- Spectral response range – (10% Q.E. points) 400 to 1000 nm
- Time response – typically 0.5 ns
- Wide operating temperature range -40°C to +70°C
- RoHS compliant

Applications

- LIDAR
- Range finding
- Small-signal fluorescence
- Photon counting
- Bar code scanning

C30902 and C30921 Series

High-speed solid state detectors for low light level applications

Table 1. Electro-optical Characteristics

Test conditions: Case temperature = 22°C, unless otherwise specification, see notes on next page.

Detector Type	C30902EH/C30902EH-2 C30902BH C30921EH			C30902SH C30902SH-2 C30921SH			C30902SH-TC C30902SH-DTC			Units
	Min	Typ	Max	Min	Typ	Max	Min	Typ	Max	
Photosensitive area										
active diameter		0.5			0.5			0.5		mm
active area		0.2			0.2			0.2		mm ²
Lightpipe characteristics (C30921)										
Numerical aperture of light pipe		0.55			0.55					[no units]
Index of refraction (n) of core		1.61			1.61					[no units]
Core diameter		0.25			0.25					mm
Field of view α (see Figure 15)										
with standard/ball lens window		90			90			122		Degrees
(-2) with built-in 905 nm filter		55			55			N/A		
with lightpipe (in air)		33			33			N/A		
Field of view α' (see Figure 15)										
with standard window/ball lens		114			114			129		Degrees
(-2) with built-in 905 nm filter		78			78			N/A		
Breakdown voltage, V_{br}		225			225			225		V
Temperature coefficient of reverse bias, V_r , voltage for constant gain	0.5	0.7	0.9	0.5	0.7	0.9	0.5	0.7	0.9	V/°C
Detector Temperature (see note 2)										
-TC								0		°C
-DTC								-20		°C
Gain (see note 1)		150			250			250		
Responsivity										
at 830 nm (not applicable for -2)	70	77		117	128			128		A/W
at 900 nm	55	65		92	108			108		A/W
Quantum efficiency										
at 830 nm (not applicable for -2)		77			77			77		%
at 900 nm		60			60			60		%
Dark current, i_d		15	30		15	30		15	30	nA
-TC (at 0 °C)								2		nA
-DTC (at -20 °C)								1		nA
Noise current, i_n (see note 3)		0.23	0.5		0.11	0.2				pA/√Hz
-TC (at 0 °C)								0.04		pA/√Hz
-DTC (at -20 °C)								0.02		pA/√Hz
Capacitance		1.6	2		1.6	2		1.6	2	pF
Rise/Fall time, $R_L=50 \Omega$										
10% to 90% points		0.5	0.75		0.5	0.75		0.5	0.75	ns
90% to 10% points		0.5	0.75		0.5	0.75		0.5	0.75	ns
TEC maximal drive current										
-TC									1.8	A
-DTC									1.4	A
TEC maximal bias voltage										
-TC									0.8	V
-DTC									2.0	V
Dark count rate at 5% photon detection probability (830 nm) (see Figure 9 and note 4)					5000	15000		1100 (-TC) 250 (-DTC)	15000	cps
Voltage above V_{br} for 5% photon detection probability (830 nm) (see Figure 7 and note 4)					2			2		V
After-pulse ratio at 5% photon detection probability (830 nm) (note 5)					2	15		2		%

C30902 and C30921 Series

High-speed solid state detectors for low light level applications

Notes:

- At the specific DC reverse operating voltage, V_{op} or V_r , supplied with each device and a light spot diameter of 0.25 mm (C30902EH, SH) or 0.10 mm (C30921EH, SH). Operated at this voltage, between 180 and 250V, the device will meet the electrical characteristic limits shown above.
- The temperature of the thermistor in Kelvin can be calculated using the following equation: $[K] = \frac{\beta}{\ln(R/r_{\infty})}$, where R is the measured thermistor resistance in Ω , $\beta = 3200$, $R_0 = 5100 \Omega$, $T_0 = 298.15 \text{ K}$ and $r_{\infty} = R_0 e^{-\frac{\beta}{T_0}} \cong 0.1113$.
- The theoretical expression for shot noise current in an avalanche photodiode is in $= (2q (I_{ds} + I_{db}M^2 + P_oRM) F) B_w)^{1/2}$ where q is the electronic charge, I_{ds} is the dark surface current, I_{db} is the dark bulk current, F is the excess noise factor, M is the gain, P_o is the optical power on the device, and B_w is the noise bandwidth. For these devices $F = 0.98 (2-1/M) + 0.02 M$. (Reference: **PP Webb, RJ McIntyre, JJ Conradi**, "RCA Review", Vol. 35 p. 234, (1974)).
- The C30902SH and C309021SH can be operated at a substantially higher detection probability. (see **Geiger Mode Operation section**).
- After-pulse occurring 1 μs to 60 seconds after main pulse.

Table 2 – Maximum Ratings

Parameter	Symbol	Min	Max	Units
Storage temperature	T_s	-60	100	$^{\circ}\text{C}$
Operating temperature	T_{op}	-40	70	$^{\circ}\text{C}$
Soldering for 5 seconds (leads only)			200	$^{\circ}\text{C}$
Reverse current at room temperature				
Average value, continuous operation			200	μA
Peak value (1 s duration, non-repetitive)			1	mA
Forward current at room temperature				
Average value, continuous operation	I_F		5	mA
Peak value (1 s duration, non-repetitive)			50	mA
Maximum Total Power Dissipation			60	mW

Electro-Optical Characteristics

Figure 1 – Typical Spectral Responsivity at case temperature of 22 $^{\circ}\text{C}$

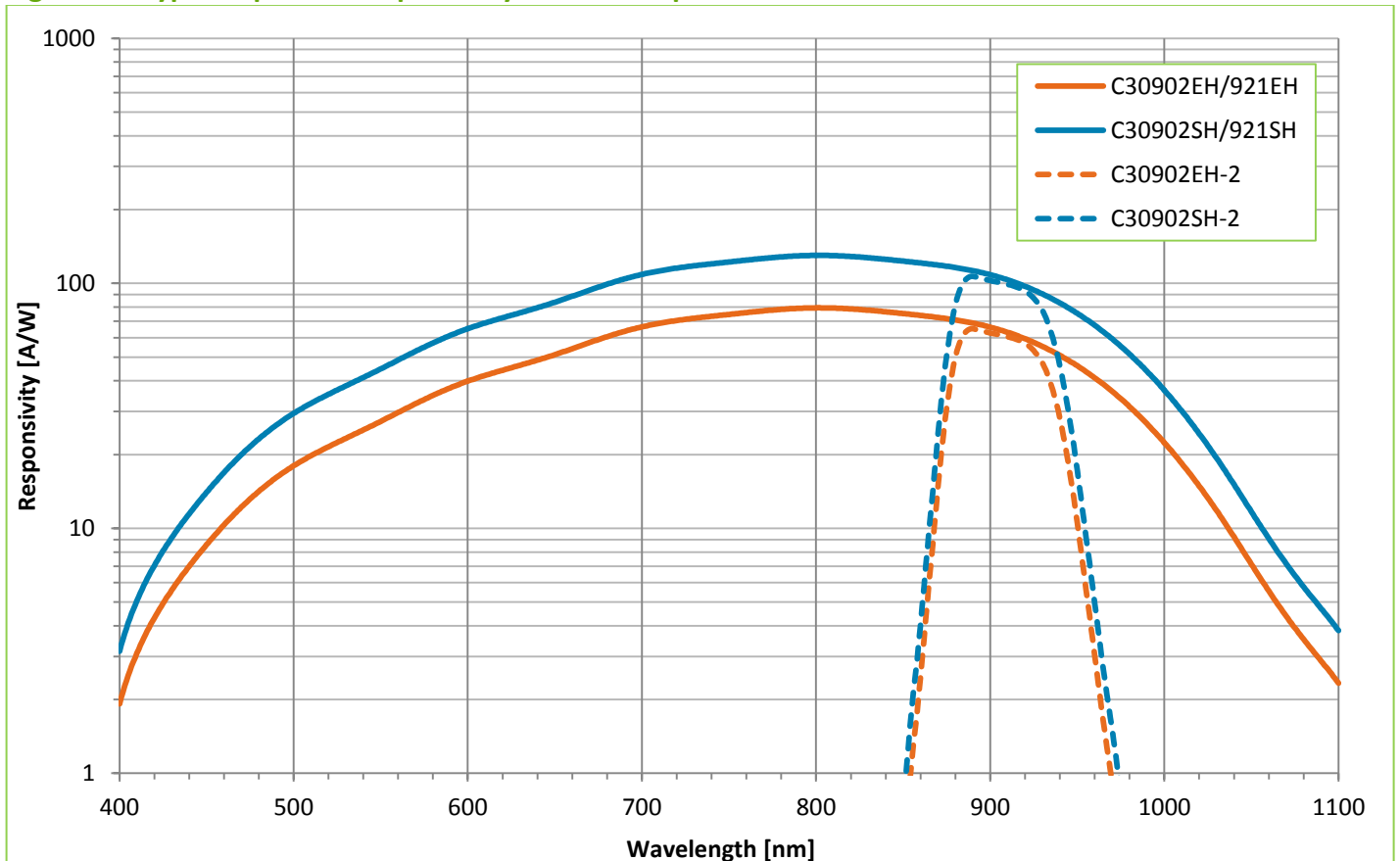

High-speed solid state detectors for low light level applications

Figure 2 – Typical quantum efficiency vs. wavelength as a function of case temperature

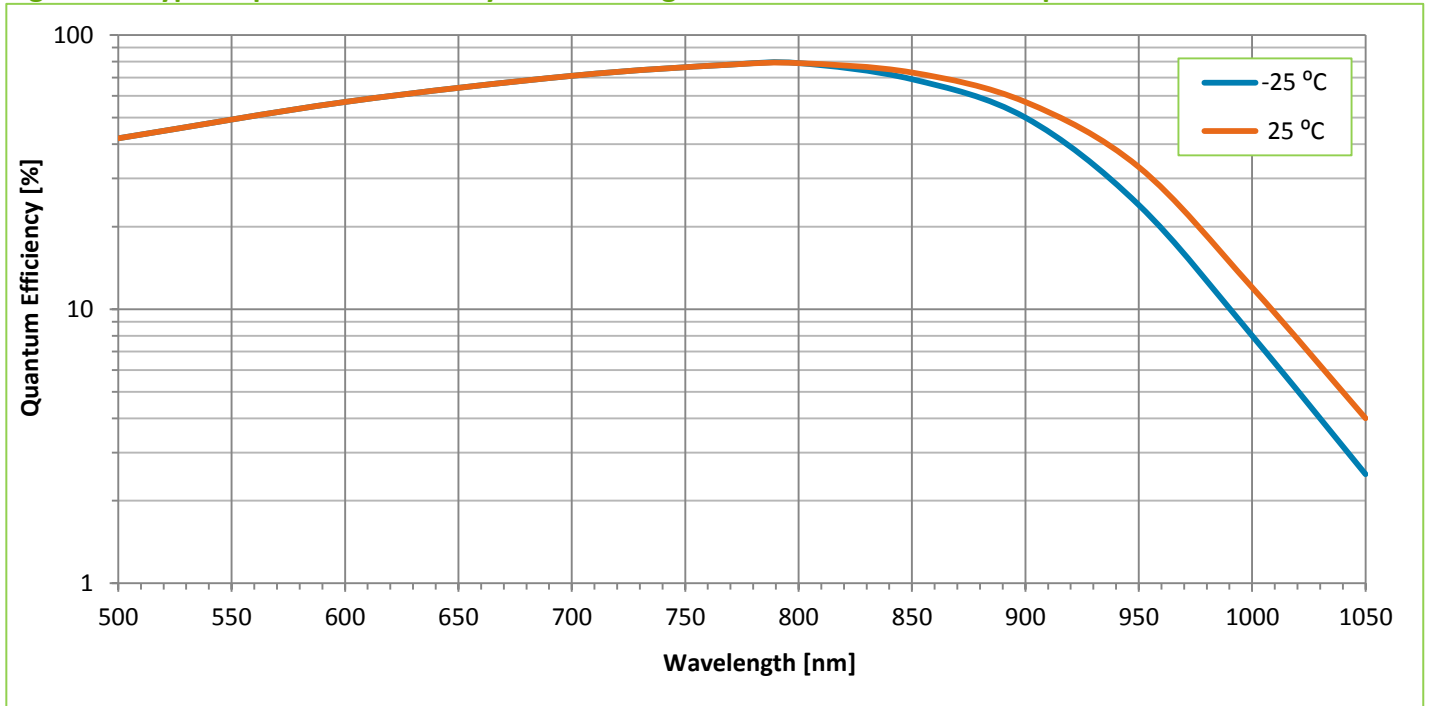
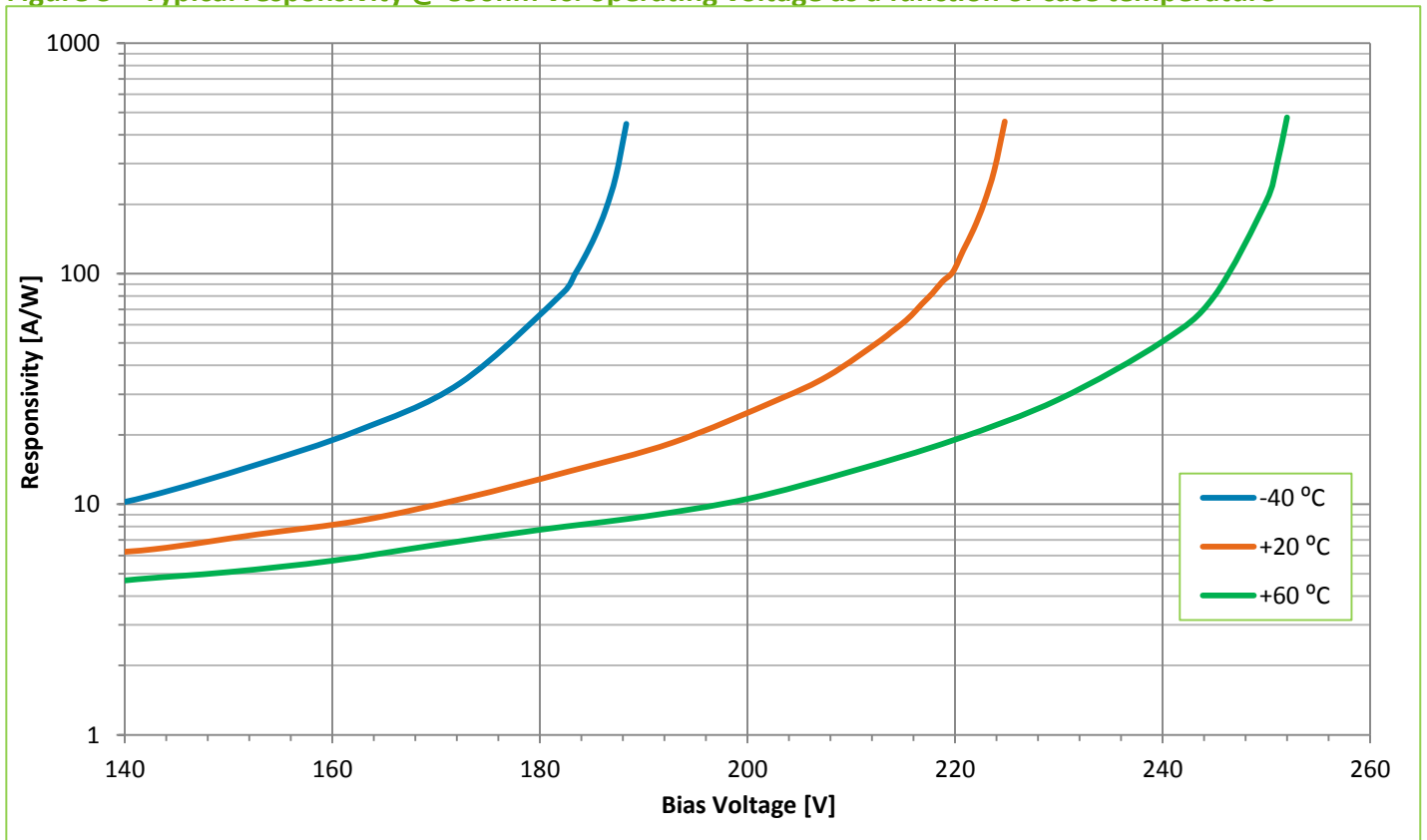

Figure 3 – Typical responsivity @ 830nm vs. operating voltage as a function of case temperature



C30902 and C30921 Series

High-speed solid state detectors for low light level applications

Figure 4 – Typical Noise current vs. Gain

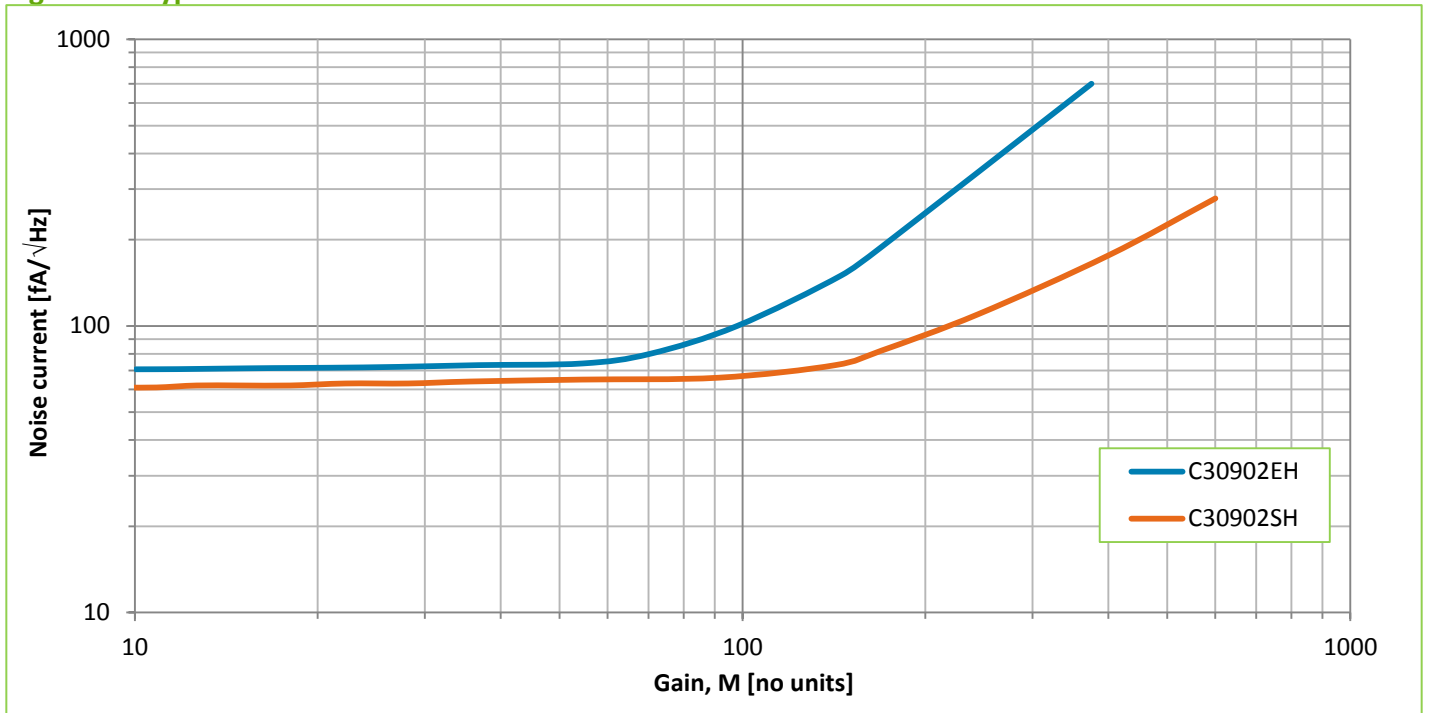
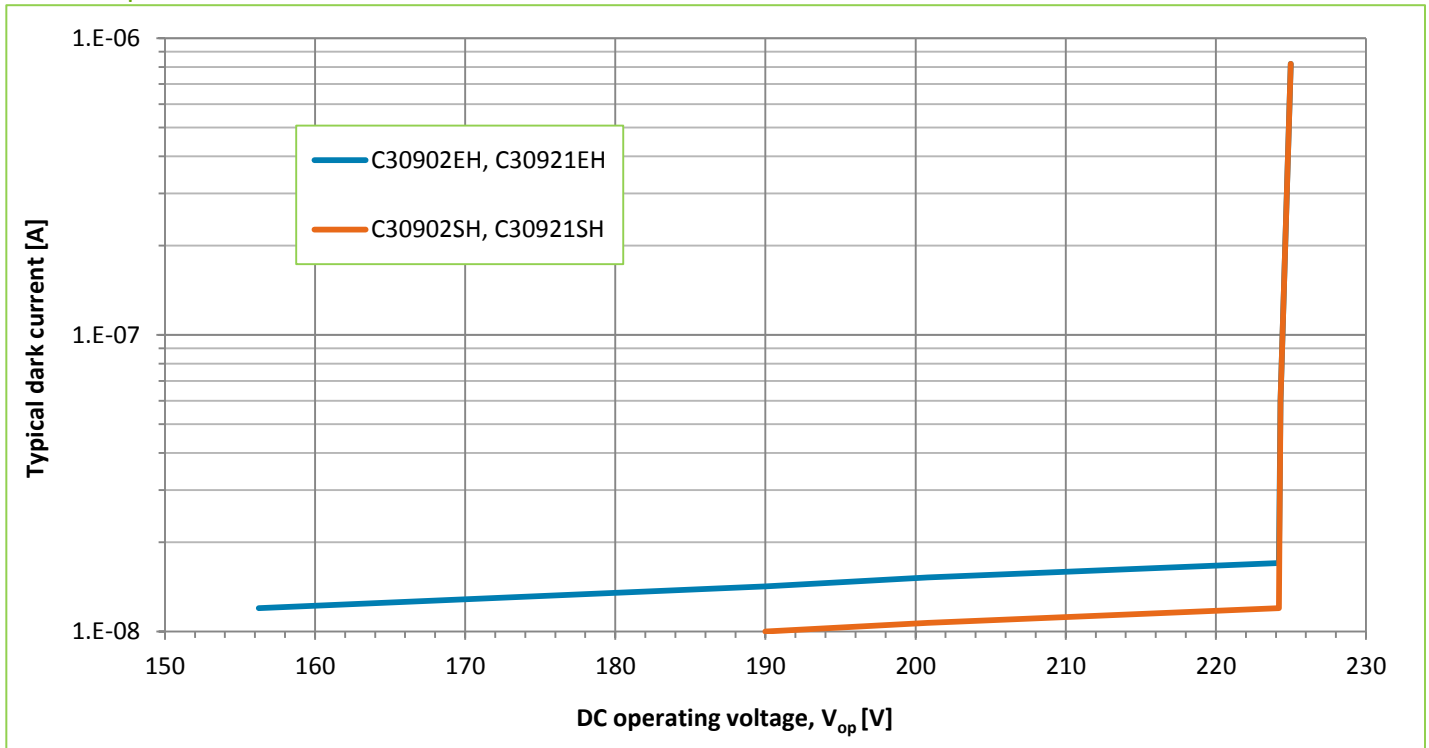

Figure 5 – Typical dark current vs. operating voltage
Case temperature of 22 °C



High-speed solid state detectors for low light level applications

Figure 6 – Typical Gain –Bandwidth Product as a function of Gain
Case temperature of 22 °C

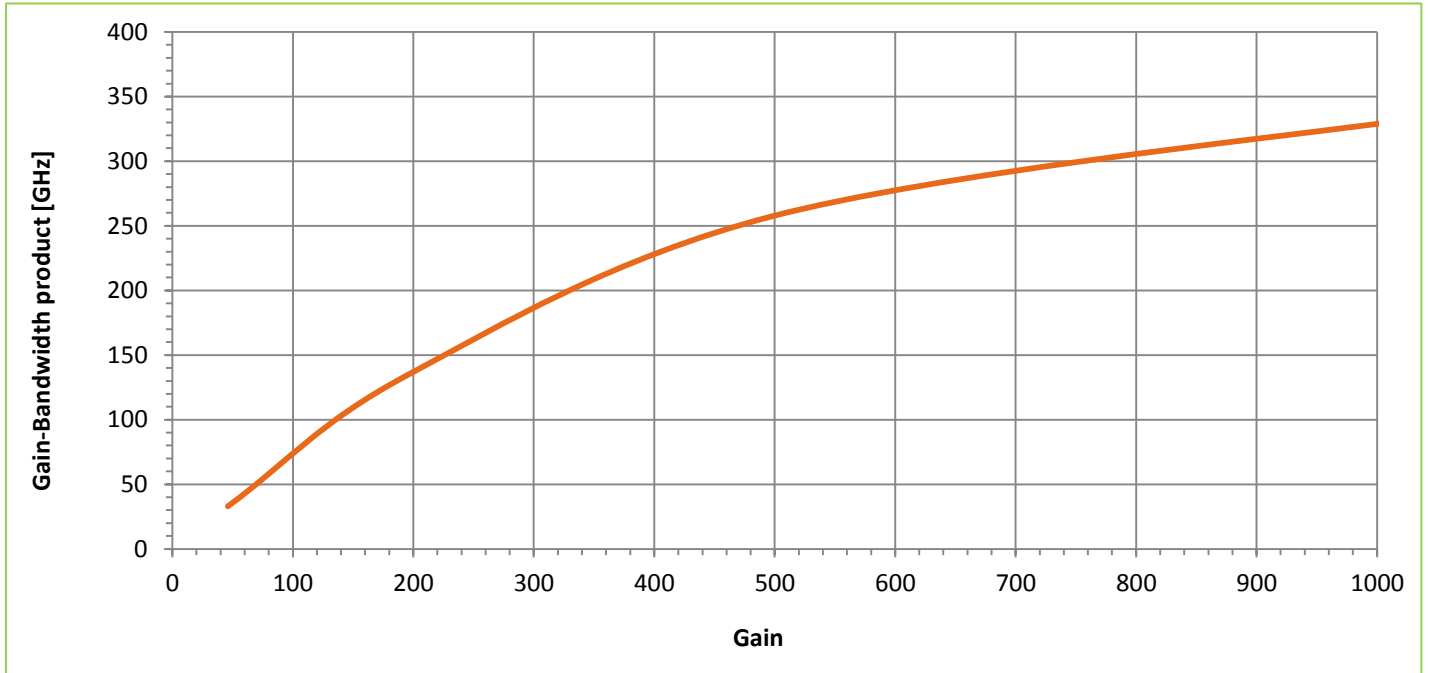
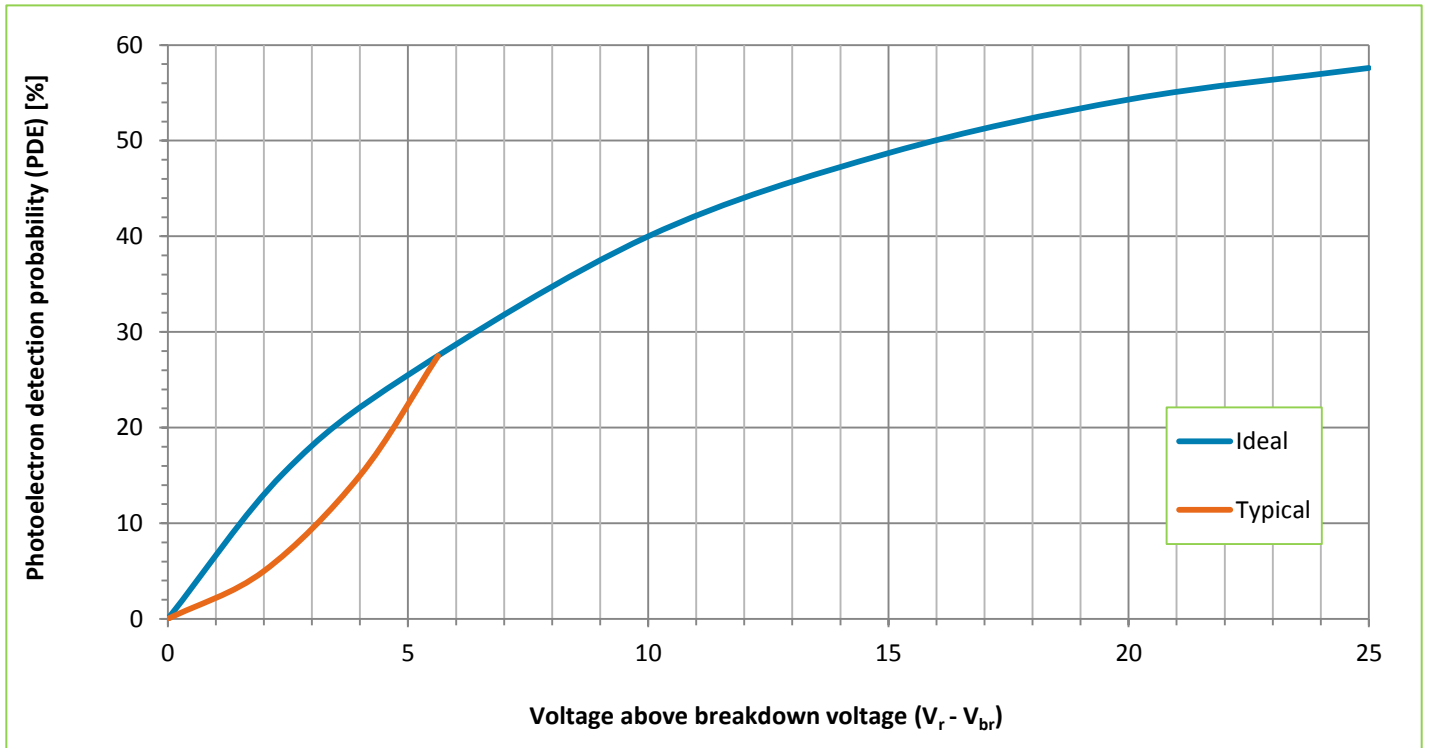

Figure 7 – Geiger mode, photoelectron detection probability @ 830nm as a function of voltage above V_{br}
Case temperature of 22 °C



High-speed solid state detectors for low light level applications

Figure 8 – Load Line for C30921SH in the Geiger mode

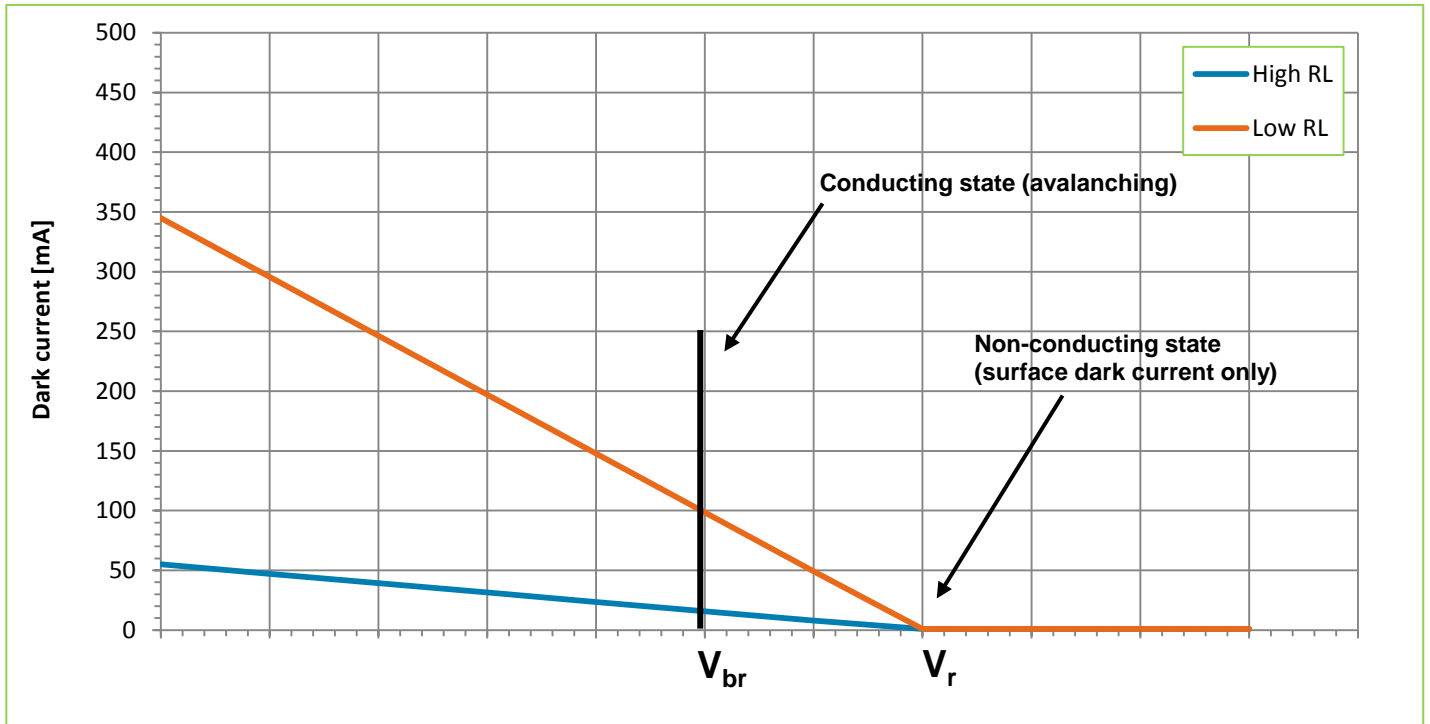
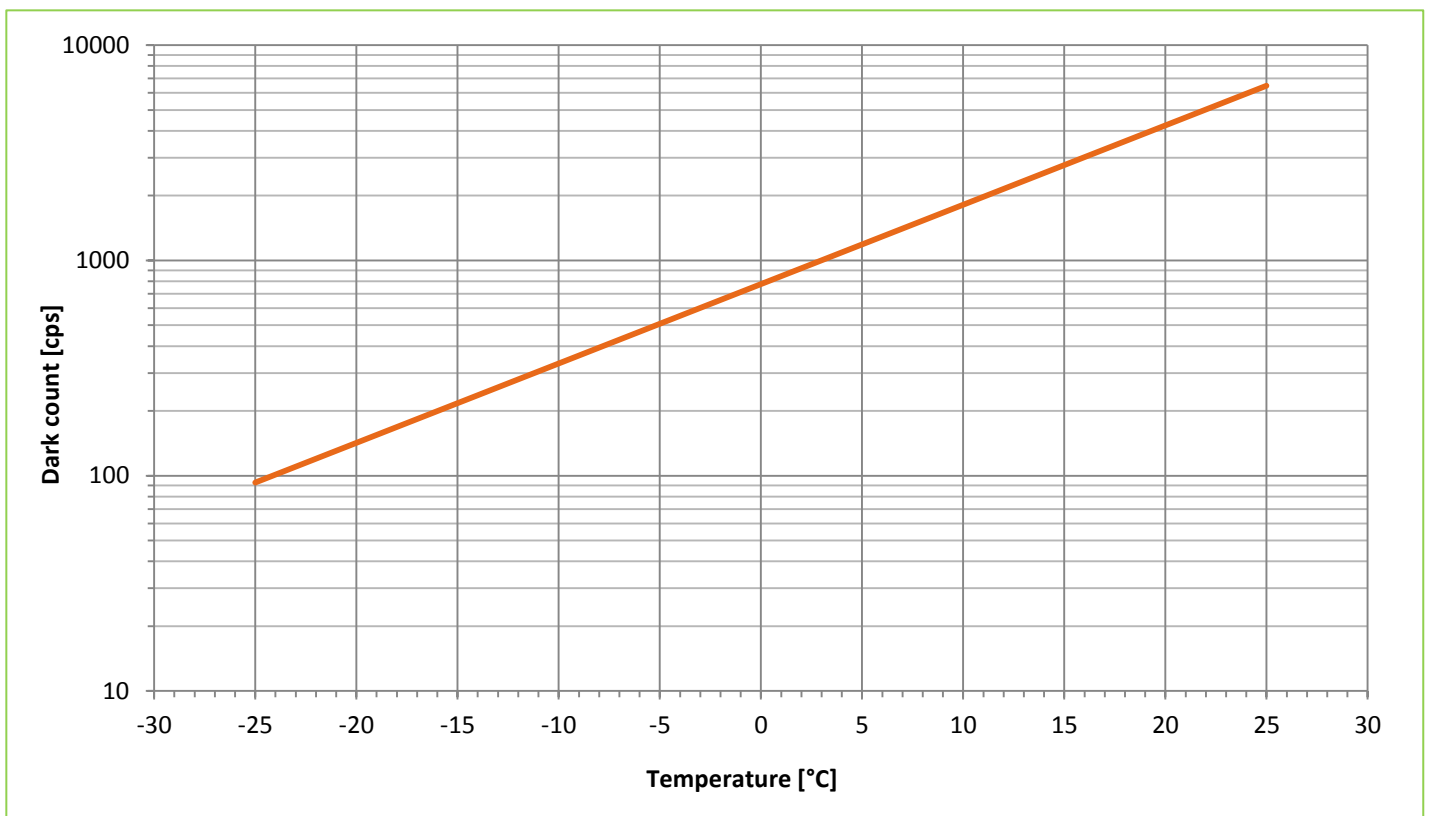

Figure 9 – Typical Dark Count vs. Temperature at 5% Photon Detection Efficiency (830nm)



C30902 and C30921 Series

High-speed solid state detectors for low light level applications

Figure 10 – Probability of after-pulse within the next 100ns vs. delay-time in an active quenched circuit (typical for C30902SH and C30921SH at V_{br} , at a case temperature of 22 °C)

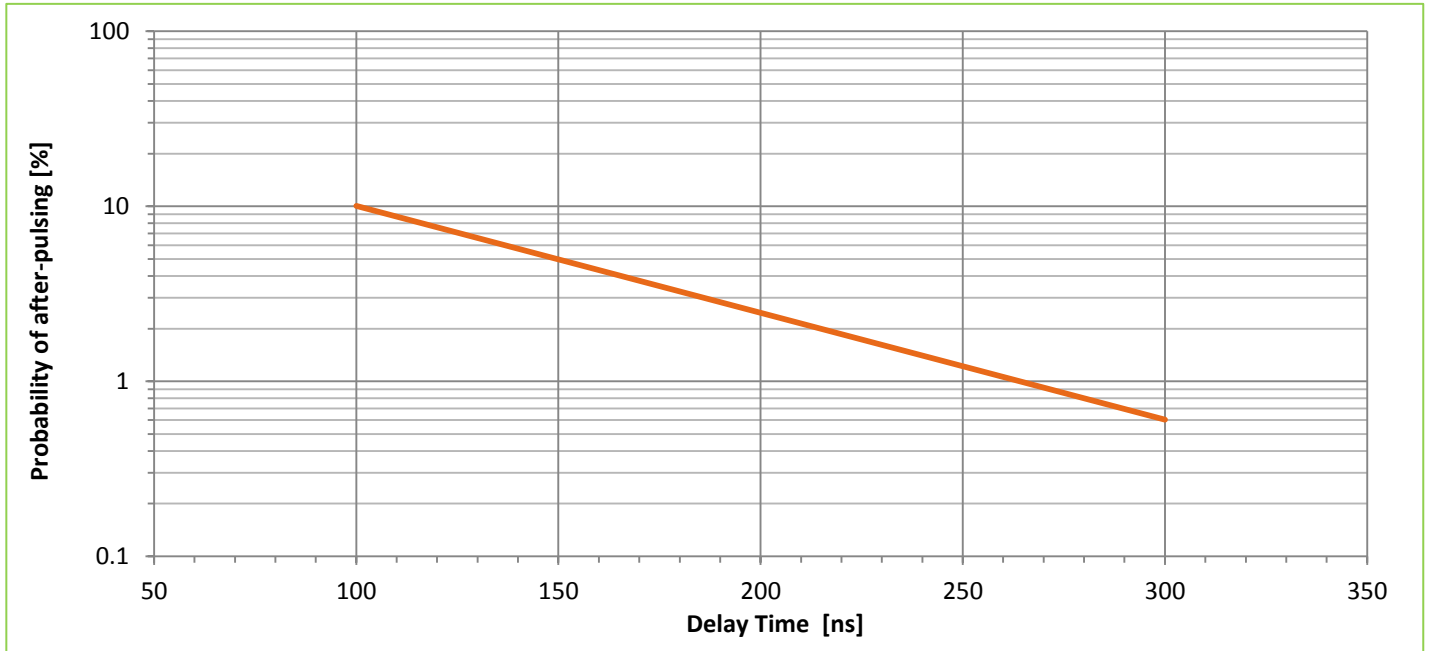

Package Drawings (Other packages available upon request)

Figure 11 – C30902EH and C30902SH, reference dimensions shown in mm (inches)

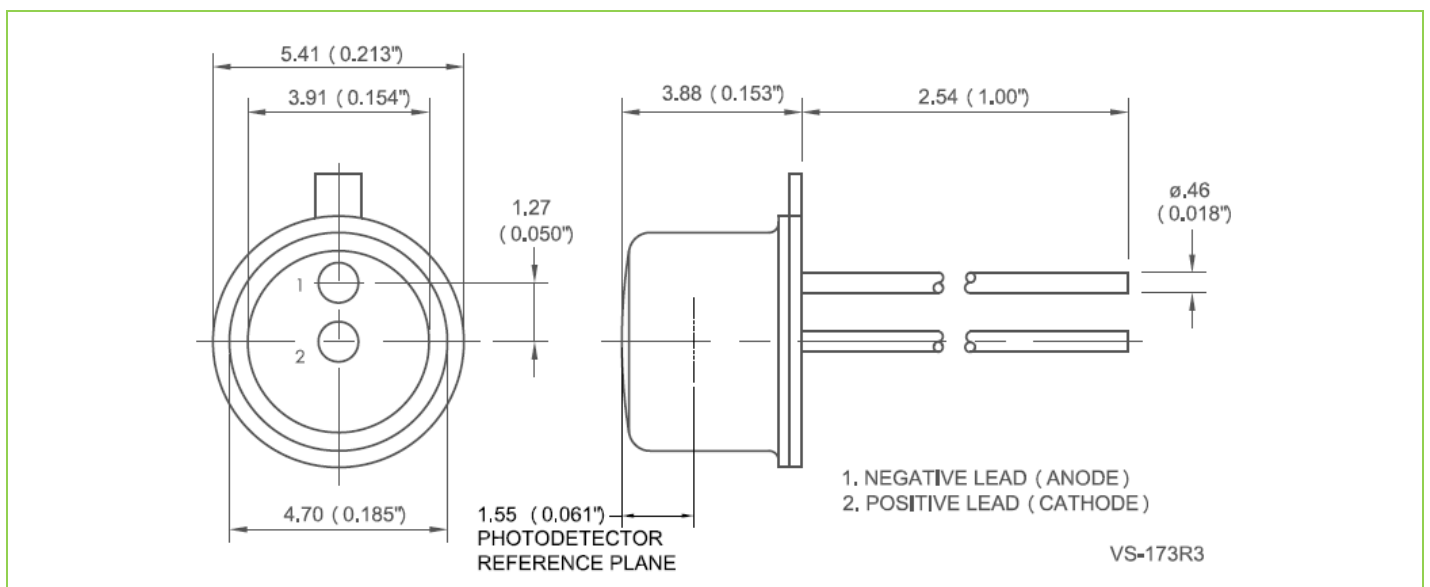

C30902 and C30921 Series

High-speed solid state detectors for low light level applications

Figure 12 – C30921EH and C30921EH, package outline and cutaway of the lightpipe, reference dimensions shown in mm [inches]

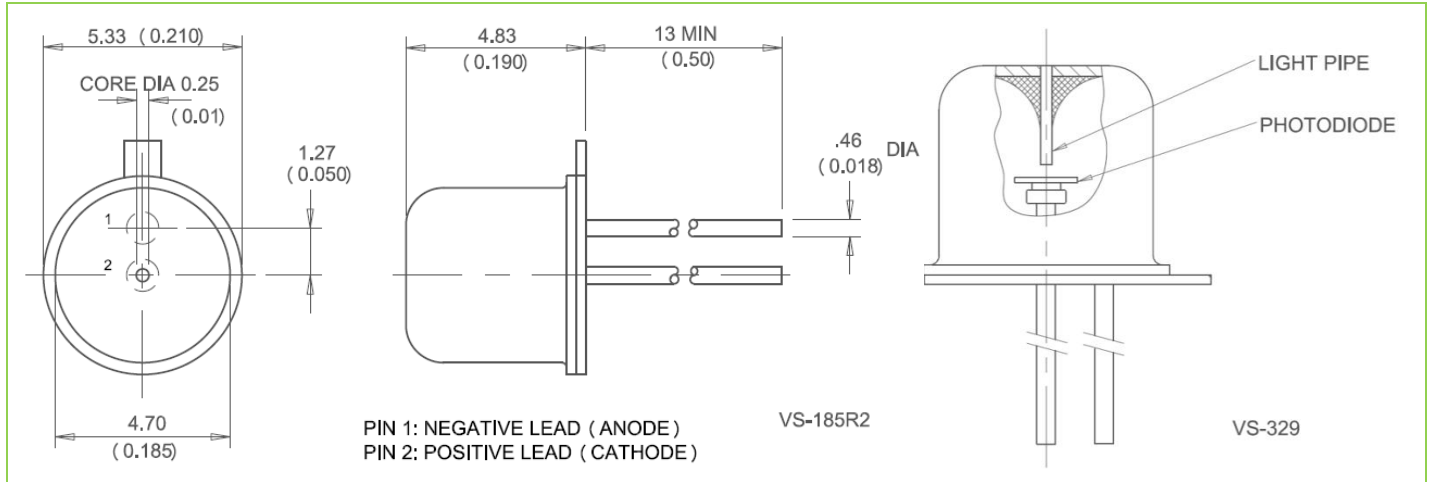
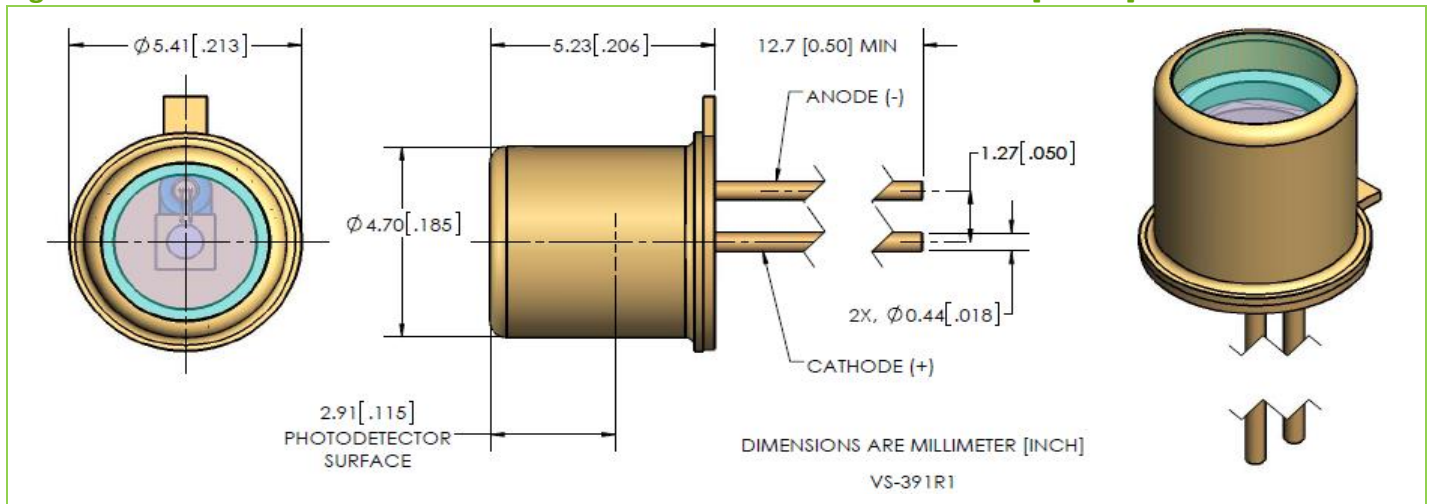

Figure 13 – C30902EH-2 and C30902SH-2 reference dimensions shown in mm [inches]



C30902 and C30921 Series

High-speed solid state detectors for low light level applications

Figure 14 – C30902BH, reference dimensions shown in mm

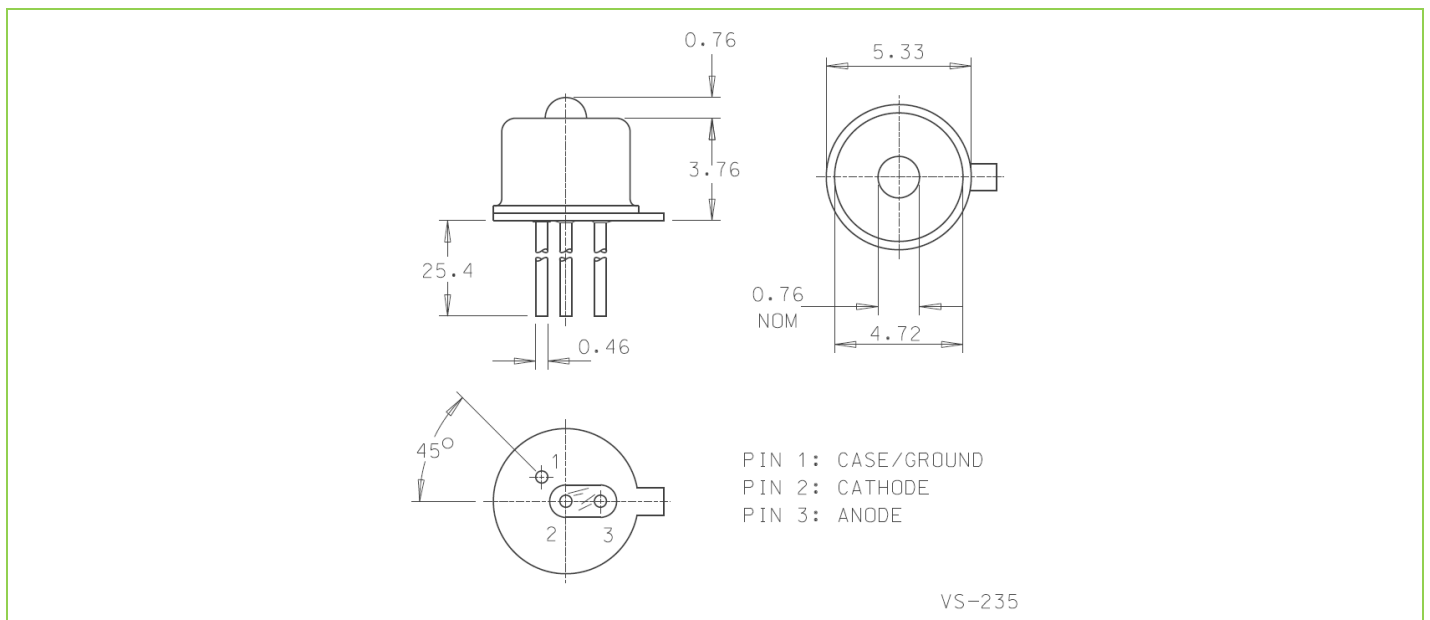
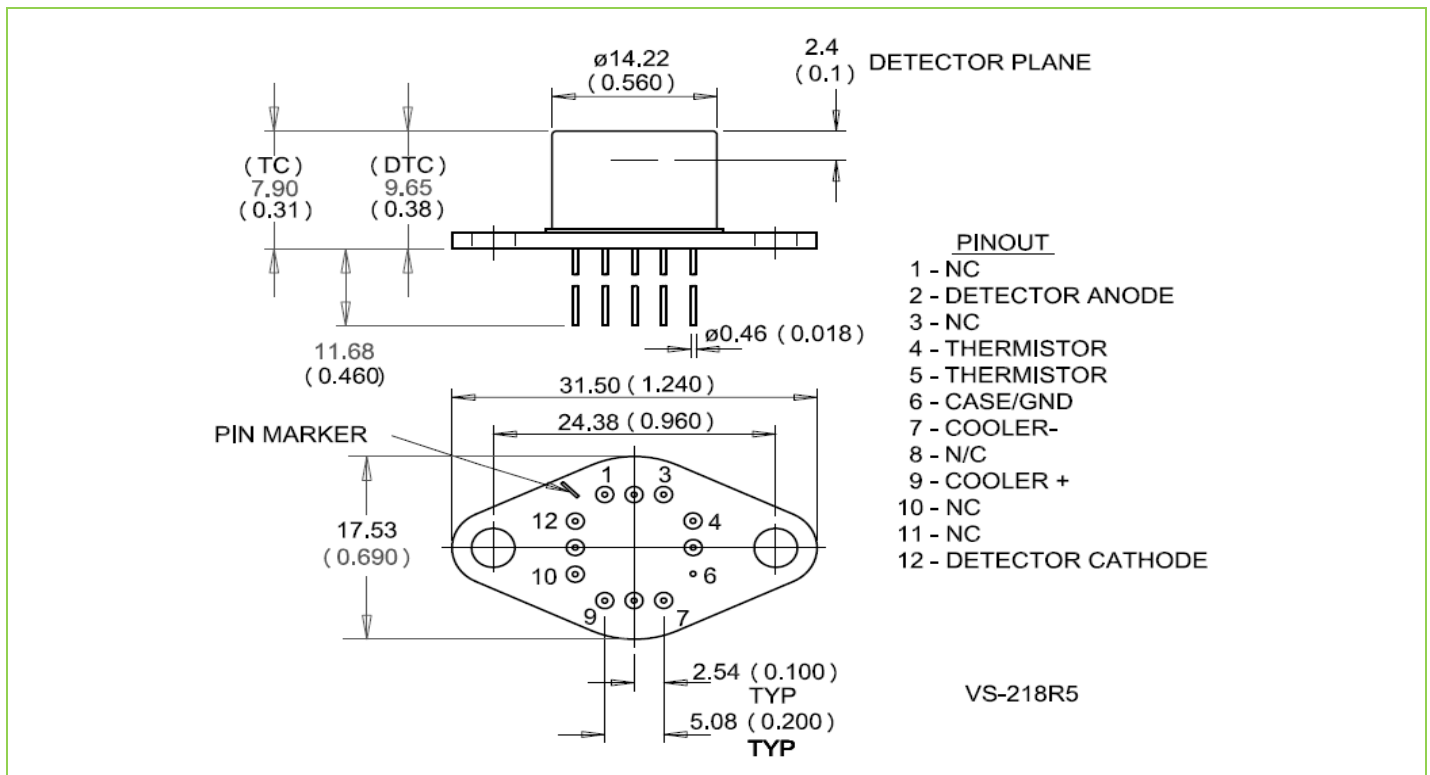

Figure 15– C30902SH-TC, C30902SH-DTC, TO-66 with flange package outline, reference dimensions shown in mm (inches)



C30902 and C30921 Series

High-speed solid state detectors for low light level applications

Figure 16 – Approximate field of view – C30902 and C30921 Series

For incident radiation at angles $\leq \alpha/2$, the photosensitive surface is totally illuminated.
For incident radiation at angles $> \alpha/2$, but $\leq \alpha'/2$, the photosensitive surface is partially illuminated

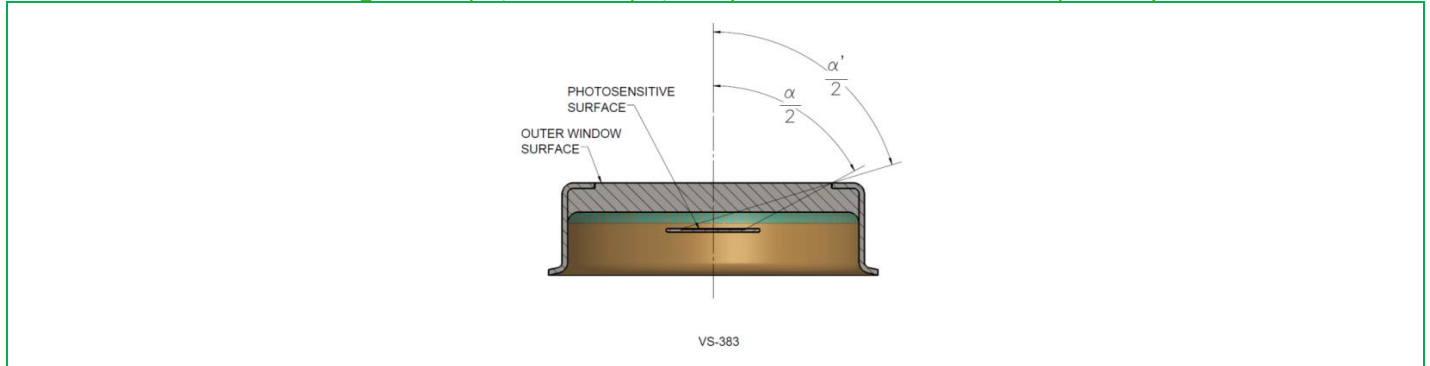

“- TC” and “- DTC” TE Cooled version

TE cooled APD can be used for different reason (**Figure 15**). Most applications benefits from a -TC (single) or -DTC (dual) version for two reasons:

1. To reduce the thermal noise for very small signal detection as described previously. The -TC version has been design to operate the APD down to 0°C whereas the -DTC version can be operated at -20°C when the ambient temperature is 22°C.
2. To keep a constant APD temperature no matter the ambient temperature. Because APD breakdown voltage decreases with a decrease of temperature, the TE cooler allows a single operating voltage. Also, this configuration allows constant APD performance over an extended ambient temperature range.

The thermistor located inside the unit can be used to monitor the APD temperature and can be used to implement a TE cooler feedback loop to keep the APD at a constant temperature or/and to implement a temperature compensation on the APD bias voltage. A proper heat-sink is required to dissipate the heat generated by the APD and the TE cooler.

Custom Designs

Recognizing that different applications have different performance requirements, Excelitas offers a wide range of customization of these APDs to meet your design challenges. Dark count selection, custom device testing and packaging are among many of the application specific solutions available

Geiger mode operation

When biased above the breakdown voltage, an avalanche photodiode will normally conduct a large current. However, if the current is such that the current is limited to less than a particular value (about 50μA for these diodes), the current is unstable and can switch off by itself. The explanation of this behavior is that the number of carriers in the avalanche region at any one time is small and fluctuating wildly. If the number happens to fluctuate to zero, the current must stop. If subsequently remains off until the avalanche pulse is retriggered by a bulk or photo-generated carrier.

The “S” versions are selected to have a small bulk-generated dark-current. This makes them suitable for low-noise operation below V_{BR} or photon-counting above V_{br} in the Geiger mode. In this so-called Geiger mode, a single photoelectron (or thermally-generated electron) may trigger an avalanche pulse which discharges the photodiode from its reverse operating voltage V_r to a voltage slightly below V_{BR} . The probability of this avalanche occurring is shown in **Figure 7** as the “Photoelectron Detection Probability” and as can be seen, it increases with reverse voltage V_r . For a given value of $V_r - V_{br}$, the Photoelectron Detection Probability is independent of Temperature. To determine the Photon Detection Probability, it is necessary to multiply the Photon Detection Probability by the Quantum Efficiency, which is shown in **Figure 2**. The Quantum Efficiency also is relatively independent of temperature, except near the 1000 nm cut-off.

The “S” versions can be used in the Geiger mode using either “passive” or “active” pulse quenching circuits. The advantages and disadvantages of each are discussed below.

High-speed solid state detectors for low light level applications

Passive-Quenching Circuit

The simplest, and in many case a perfectly adequate method of quenching a breakdown pulse, is through the use of a current limiting load resistor. An example of such a “passive” quenching is shown in **Figure 16**. The load-line of the circuit is shown in **Figure 8**. To be in the conducting state at V_{br} two conditions must be met:

1. The Avalanche must have been triggered by either a photoelectron or a bulk-generated electron entering at the avalanche region of the diode. (Note: holes are inefficient at starting avalanches in silicon.) The probability of an avalanche being initiated is discussed above.
2. To continue to be in the conducting state a sufficiently large current, called the latching current I_{LATCH} , must be passing through the device so that there is always an electron or hole in the avalanche region. Typically in the C30902SH and C30921SH, $I_{LATCH} = 50 \mu A$. For currents $(V_r - V_{br})/R_L$ much greater than I_{LATCH} , the diode remains conducting. If the current $(V_r - V_{br})/R_L$ is much less than I_{LATCH} , the diode switches almost immediately to the non-conducting state. If $(V_r - V_{br})/R_L$ is approximately equal to I_{LATCH} , then the diode will switch at an arbitrary time from the conducting to the non-conducting state depending on when the number of electrons and holes in the avalanche region statistically fluctuates to zero.

When R_L is large, the photodiode is normally conducting, and the operating point is at $V_r - I_{DS}R_L$ in the non-conducting state. Following an avalanche breakdown, the device recharges to the voltage $V_r - I_{DS}R_L$ with the time constant $R_L C$, where C is the total device capacitance including stray capacitance. Using $C = 1.6 \text{ pF}$ and $R_L = 200 \text{ k}\Omega$ a recharge time constant of $0.32 \mu s$ is calculated. The rise-time is fast, 5 to 50ns, and decreases as $V_r - V_{br}$ increases, and is very dependent on the capacitances of the load resistors, leads, etc. The jitter at the half-voltage point is typically the same order of magnitude as the rise-time. For timing purposes where it is important to have minimum jitter, the lowest possible threshold of the rising pulse should be used.

Figure 16 – Sample of passive quench circuit

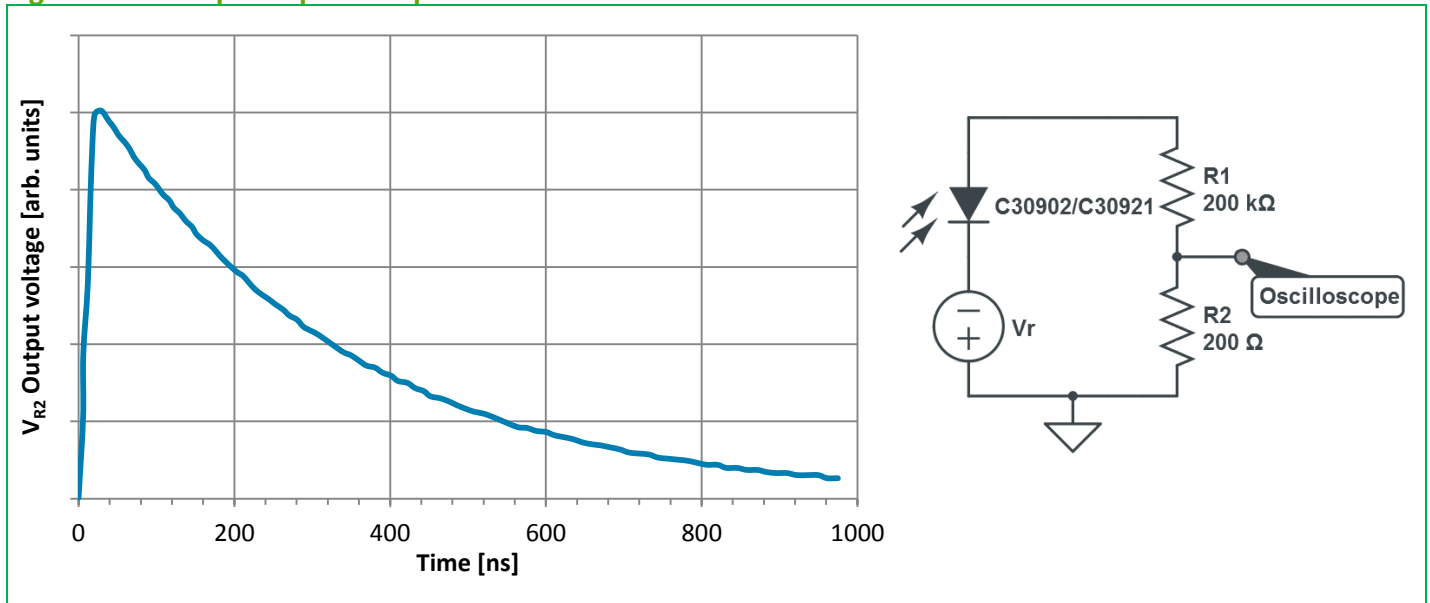

C30902 and C30921 Series

High-speed solid state detectors for low light level applications

Active-Quenching Circuit

Until the C30902SH is recharged, the probability of detecting another incoming photoelectron is relatively low. To avoid an excessive dead-time when operating at a large voltage above V_{br} , an “actively quenched” circuit can be used. The circuit temporarily drops the bias voltage for a fraction of a microsecond following the detection of an avalanche discharge. This delay time allows all electrons and holes to be collected, including most of those temporarily “trapped” at various impurity sites in the silicon. When the higher voltage is reapplied, there are no electrons in the depletion region to trigger another avalanche or latch the diode. Recharging can now be very rapid through a small load resistor. Alternatively, the bias voltage can be maintained but the load resistor is replaced by a transistor which is kept off for a short time after an avalanche, and then turned on for a period sufficient to recharge the photodiode.

Timing Resolution

For photon counting applications, the time of the TTL triggered pulse after detecting a photon, when plotted on a curve, and with the FWHM averaged, is the timing resolution or time jitter. The jitter at the half-voltage point is typically the same order of magnitude as the rise-time. For timing purposes where it is important to have minimum jitter, the lowest possible threshold of the rising pulse should be used.

After-Pulsing

An after-pulse is an avalanche breakdown pulse which follows, and is induced by, a photon-generated pulse. An after-pulse is usually caused by one of the approximately 10^8 carriers which pass through the diode during an avalanche. This electron or hole is captured and trapped at some impurity site in the silicon, as previously described. When this charge-carrier is liberated, usually in less than 100 ns but sometimes several milliseconds later, it may start another avalanche. The probability of an after-pulse occurring more than one microsecond later is typically less than 1% at 2 volts above V_{br} , using the circuit shown in **Figure 16**.

After-pulsing increases with bias voltage. If it is necessary to reduce after-pulses, it is recommended that one keep $V_r - V_{br}$ low, use an actively-quenched circuit with a long delay-line, or a passively-quenched circuit with a long $R_L C$ constant. Stray capacitances must also be minimized. Electronic gating of the signal can be performed in certain situations. Should after-pulses be a serious complication in a particular application, operation below V_{br} with a good amplifier might be considered.

Dark Current

“S” versions have been selected to have a low dark-count rate. Cooling to -25°C can reduce this by a factor of about 50, since the dependence of dark-count rate on temperature is exponential.

The dark-count increases with voltage following the same curve as the Photoelectron Detection Probability until a voltage where after-pulsing is responsible for a feedback mechanism which dramatically increases the dark-count rate. This maximum voltage is circuit dependent, and is not warranted other than the values listed on **Table 1**. In most cases, with a delay time of 300 ns, the diode can be used effectively at V_r up to $V_{br} + 25\text{V}$.

The C30902 should not be forward biased or, when unbiased, exposed to strong illumination. These conditions result in a greatly enhanced dark-count, which may require up to 24 hours returning to its nominal value.

C30902 and C30921 Series

High-speed solid state detectors for low light level applications

RoHS Compliance

The C30902 and C30921 series of avalanche photodiodes are designed and built to be fully compliant with the European Union Directive 2011/65/EU – Restriction of the use of certain Hazardous Substances (RoHS) in Electrical and Electronic equipment.



Warranty

A standard 12-month warranty following shipment applies. Any warranty is null and void if the photodiode window has been opened.

About Excelitas Technologies

Excelitas Technologies is a global technology leader focused on delivering innovative, customized solutions to meet the lighting, detection and other high-performance technology needs of OEM customers.

Excelitas has a long and rich history of serving our OEM customer base with optoelectronic sensors and modules for more than 45 years beginning with PerkinElmer, EG&G, and RCA. The constant throughout has been our innovation and commitment to delivering the highest quality solutions to our customers worldwide.

From aerospace and defense to analytical instrumentation, clinical diagnostics, medical, industrial, and safety and security applications, Excelitas Technologies is committed to enabling our customers' success in their specialty end-markets. Excelitas Technologies has approximately 3,000 employees in North America, Europe and Asia, serving customers across the world.

Excelitas Technologies
22001 Dumberry Road
Vaudreuil-Dorion, Quebec
Canada J7V 8P7
Telephone: (+1) 450 424 3300
Toll-free: (+1) 800 775 6786
Fax: (+1) 450 424 3345
detection@excelitas.com

**Excelitas Technologies
GmbH & Co. KG**
Wenzel-Jaksch-Str. 31
D-65199 Wiesbaden
Germany
Telephone: (+49) 611 492 430
Fax: (+49) 611 492 165
detection.europe@excelitas.com

Excelitas Technologies Singapore, Pte. Ltd.
8 Tractor Road
Singapore 627969
Telephone: (+65) 6775 2022 (Main number)
Telephone: (+65) 6770 4366 (Customer Service)
Fax: (+65) 6778-1752
detection.asia@excelitas.com

EXCELITAS®
TECHNOLOGIES

For a complete listing of our global offices, visit www.excelitas.com/locations

© 2014 Excelitas Technologies Corp. All rights reserved. The Excelitas logo and design are registered trademarks of Excelitas Technologies Corp. All other trademarks not owned by Excelitas Technologies or its subsidiaries that are depicted herein are the property of their respective owners. Excelitas reserves the right to change this document at any time without notice and disclaims liability for editorial, pictorial or typographical errors.