



RLE635-2-3-8



TECHNICAL DATA

Beam Expander Diode Laser Module

Small size red beam expander diode laser module at 635 nm, featuring low cost, long lifetime and small size package.

Electro-Optical Characteristics

Item	Value
Wavelength	635 nm
Output Power	2 mW
Operating Mode	CW
Beam Magnify	8 multiple magnify
Optics	Glass lens, both sides AR coated
Beam Diameter	fixed focus
Output Aperture	Ø8 mm
Operating Distance	100 m
Operating Voltage	DC 3 V
Operating Current	≤50 mA
Dimension	Ø16 x 60 mm
Wire Length	2 x 100 mm
Operating Temperature	-10 ... +40 °C
Storage Temperature	-40 ... +80 °C
Expected Life Time	≥8000 hours

Note: The above specifications are for reference purpose only and subjected to change without prior notice.

Package Dimensions

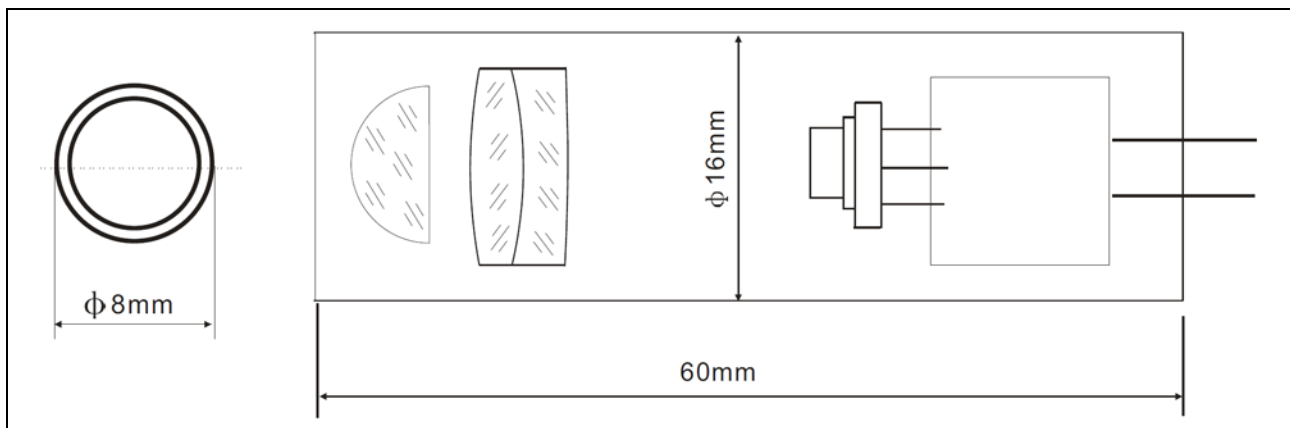



Precaution for Use

1. Safety of Laser light

- DO NOT look directly into the emitting area of the laser during operation!
- Laser Light can damage the human eyes and skin. Do not expose the eye or skin directly to any laser light and/or through optical lens. When handling the laser module, wear appropriate safety glasses to prevent laser light, even any reflections from entering to the eye. Focused laser beam through optical instruments will increase the chance of eye hazard.



2. Static Electricity

- Static electricity or electrical surges will reduce and degrade the reliability of the laser module. So it is recommended that a wrist band and/or an anti-electrostatic glove be used when handling the product.
- All devices, equipment and machinery must be grounded properly. It is recommended that precautions should be taken against surge voltage to the equipment that mounts the laser module.



3. Absolute Maximum Rating

- Active layer of LDs shall have high current density and generate high electric field during its operation. In order to prevent excessive damage, the laser module must be operated strictly below absolute maximum rating.



NOTE
LASER MODULE
MUST BE COOLED