



## QL83H6SA

- Infrared Laser Diode
- 830 nm, 20 mW
- Single transverse mode
- TO18 package, Flat Window



### Description

**QL83H6SA** is a MOCVD grown AlGaAs laser diode with quantum well structure, typically emitting at 830 nm, with a nominal output power of 20 mW. It features single mode emission and wide operating temperature range of up to 60°C. It is an efficient radiation source for many industrial applications. **QL83H6SA** comes in 5.6 mm TO-Can package **with integrated PD**.

### Maximum Rating\* ( $T_{CASE} = 25^{\circ}C$ )

Parameter	Symbol	Values		Unit
		Min.	Max.	
Optical Output Power*1	$P_O(CW)$		20	mW
LD Reverse Voltage	$V_{RLD}$		2	V
PD Reverse Voltage	$V_{RPD}$		30	V
Operating Temperature*1	$T_{OPR}$	- 30	+ 60	°C
Storage Temperature	$T_{STG}$	- 40	+ 85	°C
Soldering Temperature (max. 3s)	$T_{SOL}$		+ 260	°C

\* operating outside these conditions may damage the device

\*1 operating at maximum ratings may influence the life time



### Electro-Optical Characteristics ( $T_{CASE} = 25^{\circ}C, P_O = 20 \text{ mW}$ )

Parameter	Symbol	Values			Unit	
		Min.	Typ.	Max.		
Peak Wavelength	$\lambda_P$	820	830	840	nm	
Optical Output Power	$P_O$		20		mW	
Operating Voltage	$V_F$		1.9	2.5	V	
Threshold Current	$I_{th}$		15	30	mA	
Operating Current	$I_F$		45	70	mA	
Monitor Current	$I_M$	0.1	0.5	1.0	mA	
Slope Efficiency	$CW$	0.3	0.6	0.9	W/A	
Chip Positioning Accuracy	$\Delta X, \Delta Y, \Delta Z,$			$\pm 60$	$\mu m$	
Beam Divergence (FWHM)	parallel	$\theta_{  }$	7	9	12	deg.
	perpendicular	$\theta_{\perp}$	25	30	35	deg.
Beam Angle	parallel	$\Delta\theta_{  }$			$\pm 3$	deg.
	perpendicular	$\Delta\theta_{\perp}$			$\pm 3$	deg.



## Electrical Connection

### Pin Configuration

Pin #	Function
Pin 1	LD Cathode
Pin 2	LD Anode, PD Cathode
Pin 3	PD Anode

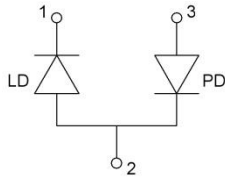

### Bottom View

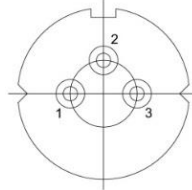

## Outline Dimensions

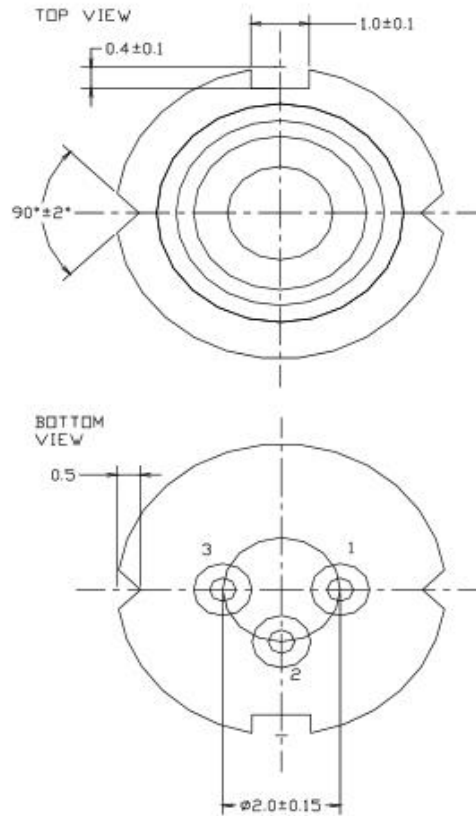
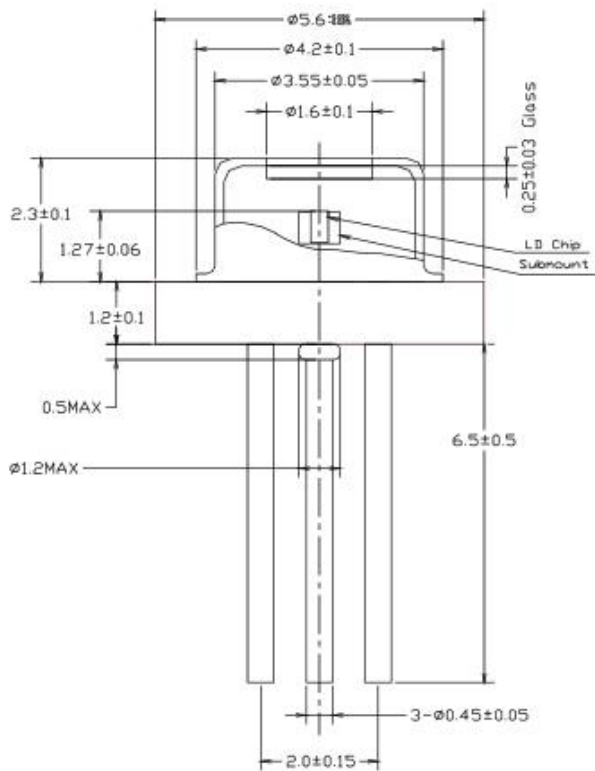

All dimensions in mm



## Precautions

### Safety

**Caution:** Laser light emitted from any laser diode may be **harmful to the human eye**. Avoid looking directly into the laser diode's aperture when the diode is in operation.

**Note:** The use of optical lenses with this laser diode will increase eye hazard

### ESD caution

Always do handle laser diodes with extreme care to **prevent electrostatic discharge**, the primary cause of unexpected diode failure. To prevent ESD related failures, it is strongly advised to always **wearing wrist straps**, and **grounding all applicable work surfaces**, when handling laser diodes

### Operating Considerations

It is strongly advised to only operate this laser diode with a current source. The current of a laser diode is an exponential function of the voltage across it. **Usage of current regulated drive circuits is mandatory.** Laser diodes may be damaged by excessive drive currents or switching transients

It is advised, to operate the laser diode at the lowest temperature possible, and to never exceed maximum specifications as outlined in the datasheet. Device degradation will accelerate with increased temperature.

**Proper heat sinking will greatly enhance stability and life time of the laser diode**

© All Rights Reserved

The above specifications are for reference purpose only and subjected to change without prior notice.