



ROITHNER LASERTECHNIK GmbH

WIEDNER HAUPTSTRASSE 76
TEL. +43 1 586 52 43 -O. FAX. -44

1040 VIENNA AUSTRIA
OFFICE@ROITHNER-LASER.COM



RLT465-3W-GOP-CL

- Blue High Power Laser Diode
- 465 nm, 3.0 W
- Collimated Laser Beam
- Multi transverse mode
- TO5 package (9mm), Flat Window



Description

RLT465-3W-GOP-CL is a blue high power multi transverse mode laser diode, typically emitting at 465 nm, with a wide operating temperature of up to 60°C. It features an integrated **aspheric AR-coated lens** for a collimated elliptical output. It is an efficient radiation source for many applications like laser projection, holography, metrology, or use in the biomedical field. **RLT465-3W-GOP-CL** comes in 9 mm TO-Can package without PD and with lens assembly.

Maximum Rating*

Parameter	Symbol	Values		Unit
		Min.	Max.	
Reverse Voltage	V_R		2	V
Operating Temperature*	T_{OPR}	- 0	+ 60	°C
Storage Temperature*	T_{STG}	- 40	+ 85	°C
Soldering Temperature (max. 3s)	T_{SOL}		+ 260	°C

* operating close to or outside these conditions may damage the device



Electro-Optical Characteristics ($T_{CASE} = 25^\circ\text{C}$)

Parameter	Symbol	Values			Unit	
		Min.	Typ.	Max.		
Peak Wavelength	λ_P	455	465	475	nm	
Optical Output Power	P_O		3.0		W	
Operating Voltage	V_F		4.5	5.5	V	
Threshold Current	I_{th}		0.4	0.7	A	
Operating Current	I_F		2.5	3.0	A	
Spatial Mode		Multi transverse mode				
Lens Type		Aspheric lens (AR-coated)				
Beam Shape		Elliptical				
Beam Divergence (FWHM)	parallel	$\theta_{ }$	0.2	0.4	0.6	deg.
	perpendicular	θ_{\perp}	-1.0	0.1	1.0	deg.





Electrical Connection

Pin Configuration (subject to change without notice)

Pin #	Function
Pin 1	LD Anode
Pin 2	LD Cathode

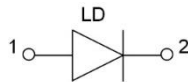

Bottom View

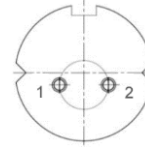

Outline Dimensions

T05

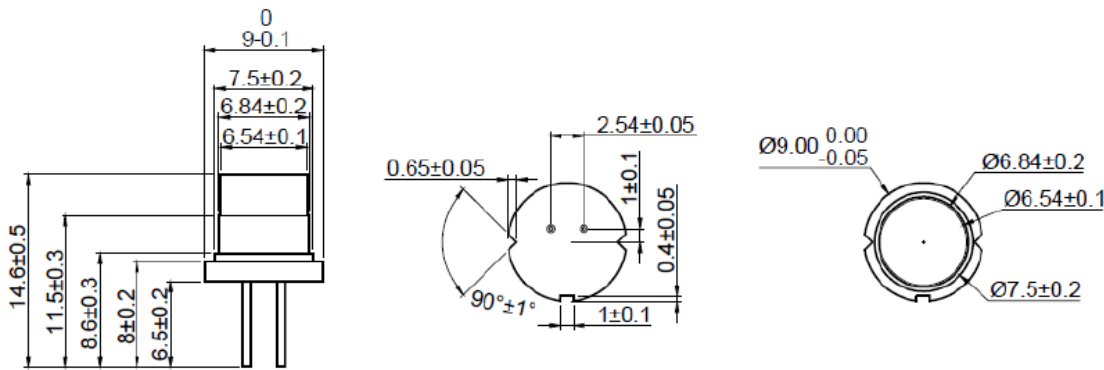

All dimensions in mm

Precautions

Safety

Caution: This laser diode emits highly concentrated light which can be **hazardous to the human eye and skin**. This diode is classified as **CLASS 4 laser product** according to **IEC 60825-1** and **21 CFR Part 1040.10 Safety Standards**.

Note: The use of optical lenses with this laser diode will increase eye hazard

ESD caution

Always do handle laser diodes with extreme care to **prevent electrostatic discharge**, the primary cause of unexpected diode failure. To prevent ESD related failures, it is strongly advised to always **wearing wrist straps**, and **grounding all applicable work surfaces**, when handling laser diodes

Operating considerations

It is strongly advised to only operate this laser diode with a current source. The current of a laser diode is an exponential function of the voltage across it. **Usage of current regulated drive circuits is mandatory**. Laser diodes may be damaged by excessive drive currents or switching transients

Proper heat sinking will greatly enhance stability and lifetime of the laser diode