



RLT520-80MGS

- Green Laser Diode
- 520 nm, 80 mW
- Single transverse mode
- TO18 package, Flat Window



Description

RLT520-80MGS is a green FP laser diode, typically emitting at 520 nm. It features **single transverse mode** emission and wide operating temperature range of up to 60°C. It is an efficient radiation source for many applications like laser projection, holography, metrology, or use in the biomedical field. **RLT520-80MGS** comes in 5.6 mm TO-Can package **with integrated PD**.

Maximum Rating* ($T_{CASE} = 25^{\circ}C$)

Parameter	Symbol	Values		Unit
		Min.	Max.	
Reverse Voltage	V_R		2	V
Operating Temperature*	T_{OPR}	- 20	+ 60	°C
Storage Temperature*	T_{STG}	- 40	+ 85	°C
Soldering Temperature (max. 3s)	T_{SOL}		+ 260	°C

* operating close to or outside these conditions may damage the device

Electro-Optical Characteristics ($T_{CASE} = 25^{\circ}C$)

Parameter	Symbol	Values			Unit	
		Min.	Typ.	Max.		
Peak Wavelength	λ_P	510	520	530	nm	
Optical Output Power	P_O		80		mW	
Spectral Width (FWHM)	λ		2.0		nm	
Operating Voltage	V_F		7.0	8.0	V	
Threshold Current	I_{th}		55	80	mA	
Operating Current	I_F		160	180	mA	
Monitor Current	I_{PD}		100		μA	
Slope Efficiency			0.3		W/A	
Beam Divergence (FWHM)	parallel	$\theta_{ }$	5	8	10	deg.
	perpendicular	θ_{\perp}	20	22	26	deg.





Electrical Connection

Pin Configuration

Pin #	Function
1	LD Cathode
2	LD Anode, PD Cathode
3	PD Anode

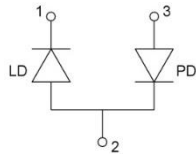

Bottom View

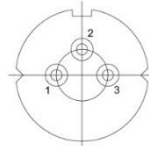

Outline Dimensions

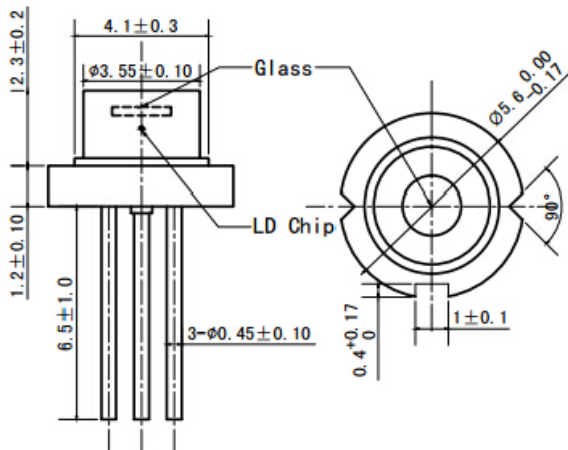

All dimensions in mm



Precautions

Safety

Caution: Laser light emitted from any laser diode may be **harmful to the human eye**. Avoid looking directly into the laser diode's aperture when the diode is in operation.

Note: The use of optical lenses with this laser diode will increase eye hazard



ESD caution

Always do handle laser diodes with extreme care to **prevent electrostatic discharge**, the primary cause of unexpected diode failure. To prevent ESD related failures, it is strongly advised to always **wearing wrist straps**, and **grounding all applicable work surfaces**, when handling laser diodes

Operating Considerations

It is strongly advised to only operate this laser diode with a current source. The current of a laser diode is an exponential function of the voltage across it. **Usage of current regulated drive circuits is mandatory.** Laser diodes may be damaged by excessive drive currents or switching transients

It is advised, to operate the laser diode at the lowest temperature possible, and to never exceed maximum specifications as outlined in the datasheet. Device degradation will accelerate with increased temperature. **Proper heat sinking will greatly enhance stability and life time of the laser diode**