



G7NU5111A

TECHNICAL DATA



Yellow LED 5 mm

Features

- High Luminous LEDs
- 5mm Round Standard Directivity
- Superior Weather-resistance
- UV Resistant Epoxy
- Water Clear Type

Applications

- Electronic Signs And Signal
- Small Area Illuminations
- Back Lighting
- Other Lighting

Directivity:

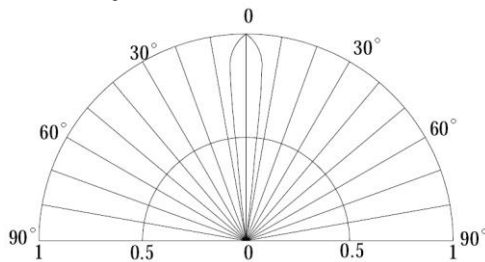

Outline Dimension:

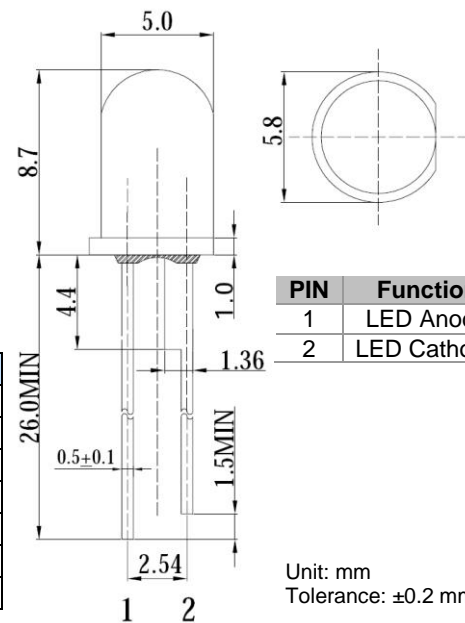

Absolute Maximum Ratings (T_a=25°C)

Item	Symbol	Value	Unit
Power Dissipation	P _D	78	mW
Forward Current	I _F	30	mA
Pulse Forward Current *	I _{FP}	100	mA
Reverse Voltage	V _R	5	V
Operating Temperature	T _{opr}	-30 ... +85	°C
Storage Temperature	T _{stg}	-40 ... +100	°C
Soldering Temperature (5 sec.)	T _{sol}	260	°C

* pulse width max. 10 ms, duty ratio max. 1/10

Specifications (T_a=25°C)

Item	Condition	Symbol	Min.	Typ.	Max.	Unit
Optical Specifications						
Luminous Intensity * ²	I _F = 20 mA	I _V	750	1120		mcd
Dominant Wavelength * ¹	I _F = 20 mA	λ _D	560	565	566	nm
Viewing Angle	I _F = 20 mA	2Θ _{1/2}		15		deg
Electrical Specifications						
Forward Voltage * ³	I _F = 20 mA	V _F	1.8	2.1	2.6	V
Reverse Voltage	V _F = 5 V	I _R			10	μA

*¹ Tolerance of measurements of dominant wavelength is ±1 nm

*² Tolerance of measurements of luminous intensity is ±15%

*³ Tolerance of measurements of forward voltage is ±0.1 V



Precaution for Use

1. Cautions

- DO NOT look directly into the light or look through the optical system.

2. Lead Forming

- When forming leads, the leads should be bent at a point at least 3 mm from the base of the lead. DO NOT use the base of the leadframe as a fulcrum during lead forming.
- Lead forming should be done before soldering.
- DO NOT apply any bending stress to the base of the lead. The stress to the base may damage the LED's characteristics or it may break the LEDs.
- When mounted the LEDs onto the printed circuit board, the holes on the circuit board should be exactly aligned with the leads of LEDs. If the LEDs are mounted with stress at the leads, it causes deterioration of the lead and it will degrade the LEDs.

3. Soldering Conditions

- Solder the LEDs no closer than 3 mm from the base of the lead.
- Recommended soldering conditions:

Dip Soldering	
Pre-Heat	120 °C Max.
Pre-Heat Time	60 Seconds Max.
Solder Bath Temperature	260 °C Max.
Dipping Time	5 Seconds Max.
Dipping Position	No lower than 3 mm from the base of the epoxy bulb

- DO NOT apply any stress to the lead particularly when heat.
- The LEDs must not be reposition after soldering.
- After soldering the LEDs, the lead should be protected from mechanical shock or vibration until the LEDs return to room temperature.
- When it is necessary to clamp the LEDs to prevent soldering failure, it is important to minimize the mechanical stress on the LEDs.
- Cut the LED leads at room temperature. Cutting the leads at high temperature may cause the failure of the LEDs.

4. Static Electricity

- The LEDs are very sensitive to Static Electricity and surge voltage. So it is recommended that a wrist band or an anti-electrostatic glove be used when handling the LEDs.
- All devices, equipment and machinery must be grounded properly. It is recommended that precautions should be taken against surge voltage to the equipment that mounts the LEDs.

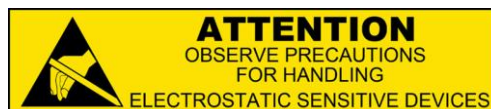

5. Heat Generation

- The powered LEDs generate heat. Heat dissipation should be considered in the application design to avoid the environmental conditions for operation in excess of the absolute maximum ratings.