



LED750-03AU

- Infrared LED
- 750 nm, 25 mW
- Chip: AlGaAs, 400 x 400 μm
- 5 mm Clear Molding, Epoxy Resin
- Viewing Angle: 20°



Description



LED750-03AU contains one AlGaAs LED chip die mounted on a lead frame hermetically sealed with a clear epoxy lens.

On forward bias, it emits a power radiation of typical **25 mW** at a peak wavelength at **750 nm**.

Maximum Ratings ($T_{\text{CASE}}=25^{\circ}\text{C}$)

Parameter	Symbol	Values		Unit
		Min.	Max.	
Power Dissipation	P_D		200	mW
Forward Current	I_F		100	mA
Pulse Forward Current *1	I_{FP}		500	mA
Reverse Voltage	V_F		5	V
Thermal Resistance	R_{THJA}		240	K/W
Junction Temperature	T_J		120	$^{\circ}\text{C}$
Operating Temperature	T_{CASE}	- 40	+ 100	$^{\circ}\text{C}$
Storage Temperature	T_{STG}	- 40	+ 100	$^{\circ}\text{C}$
Lead Solder Temperature *2	T_{SLD}		+ 265	$^{\circ}\text{C}$

*1 duty=1%, pulse width = 10 μs

*2 must be completed within 3 seconds

Electro-Optical Characteristics ($T_{\text{CASE}}=25^{\circ}\text{C}$)

Parameter	Symbol	Conditions	Values			Unit
			Min.	Typ.	Max.	
Peak Wavelength	λ_P	$I_F=50\text{mA}$	740		760	nm
Half Width	$\Delta\lambda$	$I_F=50\text{mA}$		25		nm
Forward Voltage	V_F	$I_F=50\text{mA}$		1.7	2.0	V
	V_{FP}	$I_{FP}=500\text{mA}$		3.6		
Radiated Power *1	P_O	$I_F=50\text{mA}$		25		mW
		$I_{FP}=500\text{mA}$		240		
Radiant Intensity *2	I_E	$I_F=50\text{mA}$		190		mW/sr
		$I_{FP}=500\text{mA}$		1800		
Viewing Angle	φ	$I_F=50\text{mA}$		20		deg.
Rise Time	t_R	$I_F=50\text{mA}$		10		ns
Fall Time	t_F	$I_F=50\text{mA}$		20		ns

*1 measured by S3584,08

*2 measured by CIE127-2007 Condition B



Typical Performance Curves

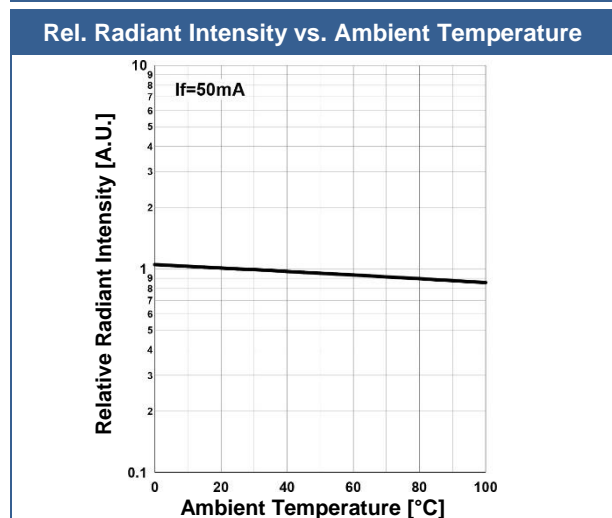
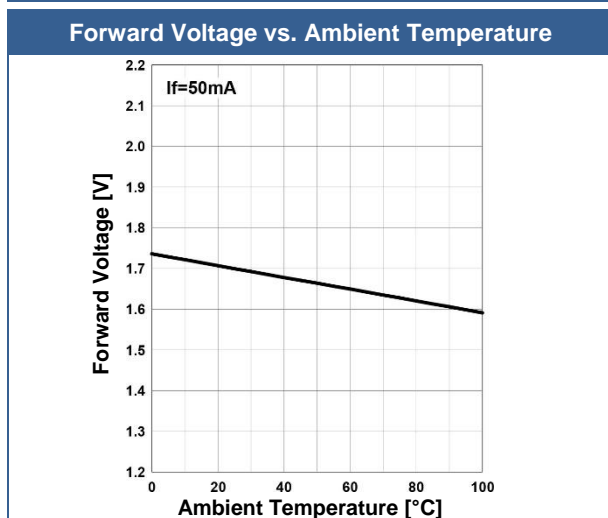
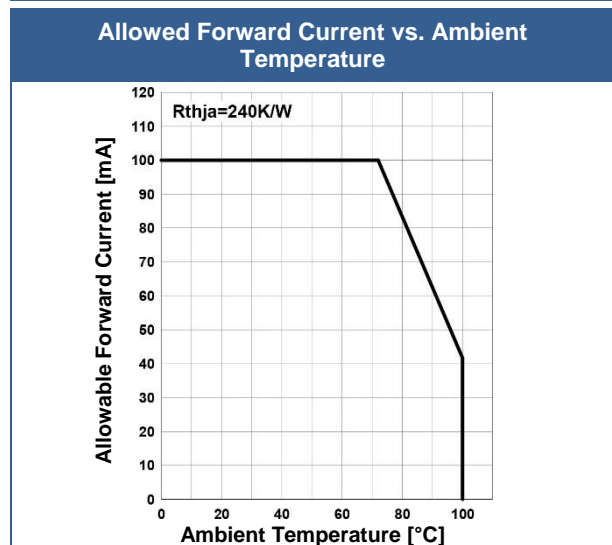
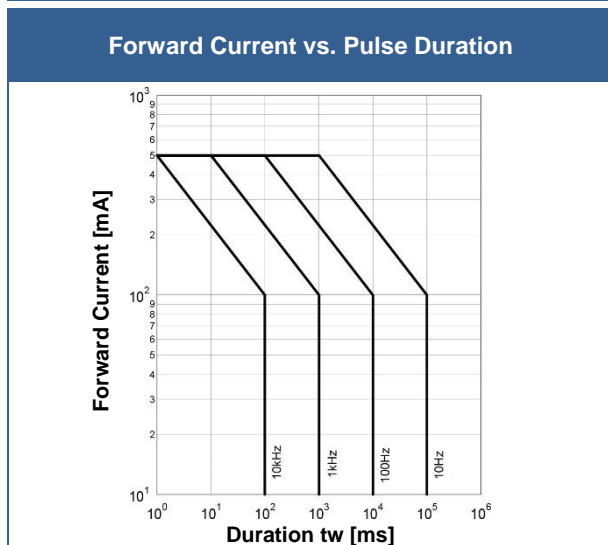
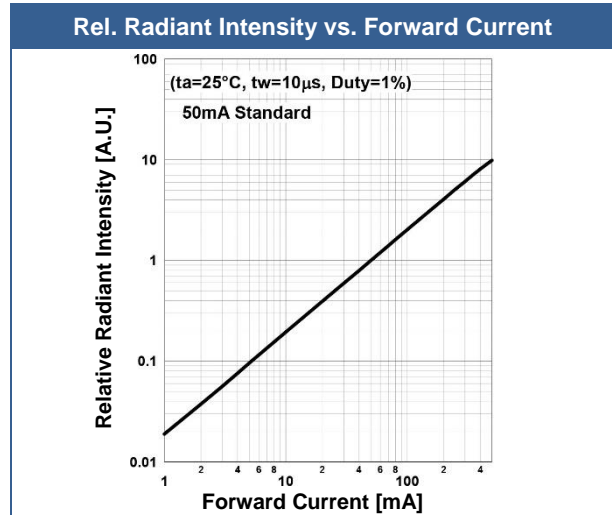
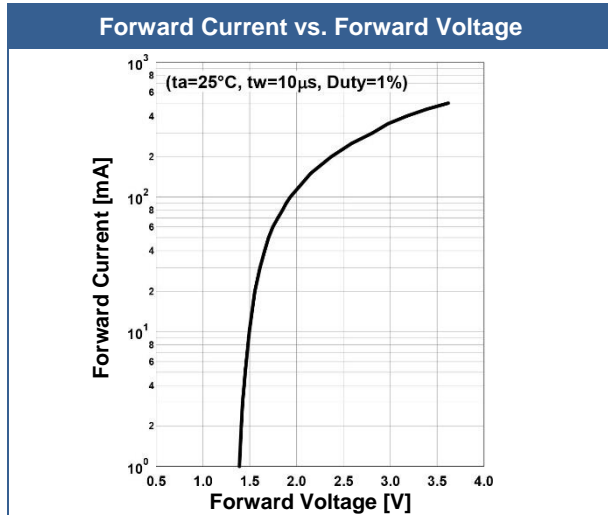



Peak Wavelength vs. Ambient Temperature

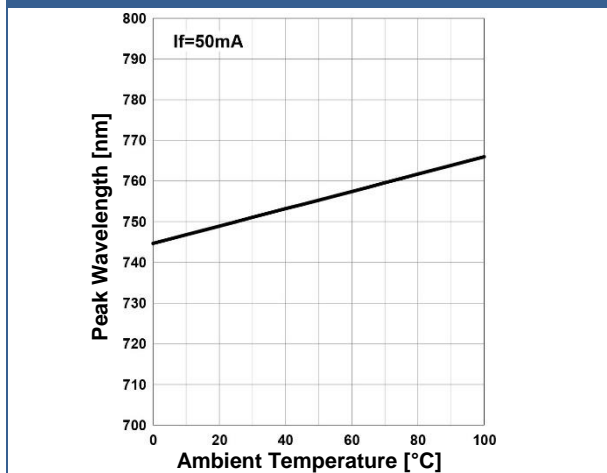

Relative Spectral Emission

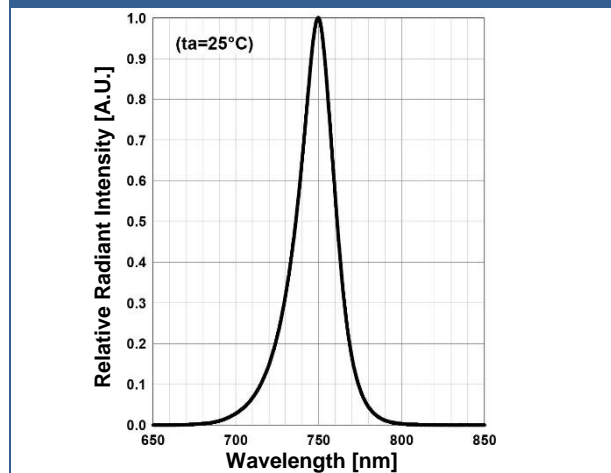

Radiation Characteristics

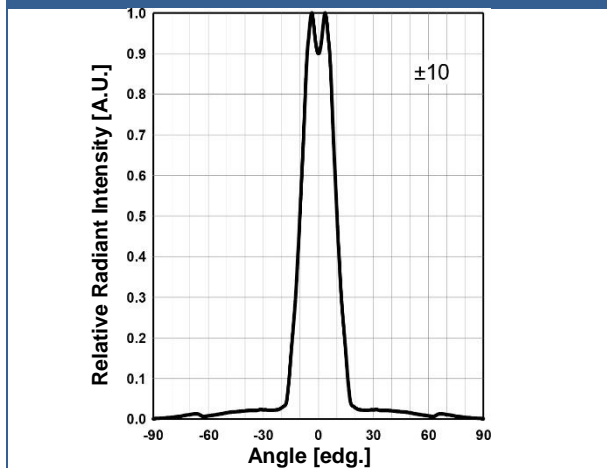

Radiation Characteristics

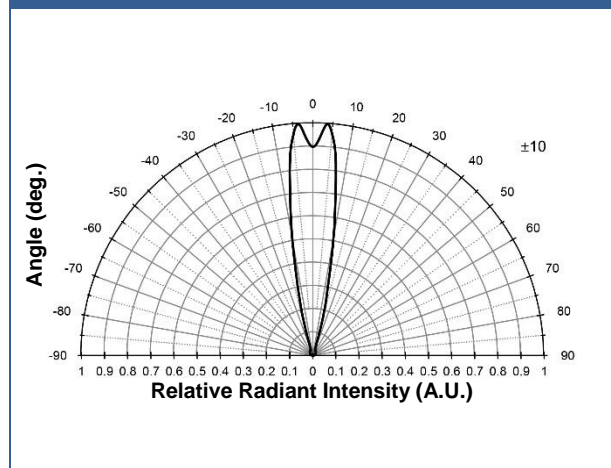

Outline Dimensions

LED750-03AU

5 mm

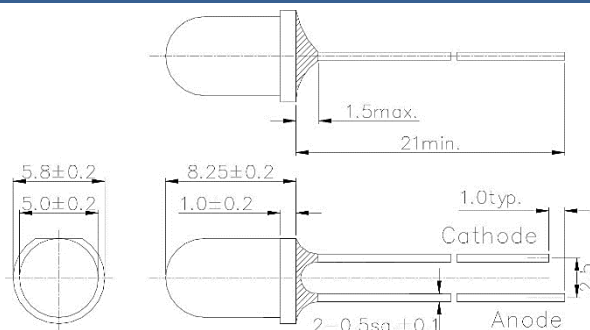

Lead	Description
Short Pin	LED Cathode
Long Pin	LED Anode

All Dimensions in mm



Precautions

Soldering:

- Do avoid overheating of the LED
- Do avoid electrostatic discharge (ESD)
- Do avoid mechanical stress, shock, and vibration
- Do only use non-corrosive flux
- Do not apply current to the LED until it has cooled down to room temperature after soldering
- Do not solder the LED closer than 3 mm from the base of the lead.

Recommended soldering conditions:

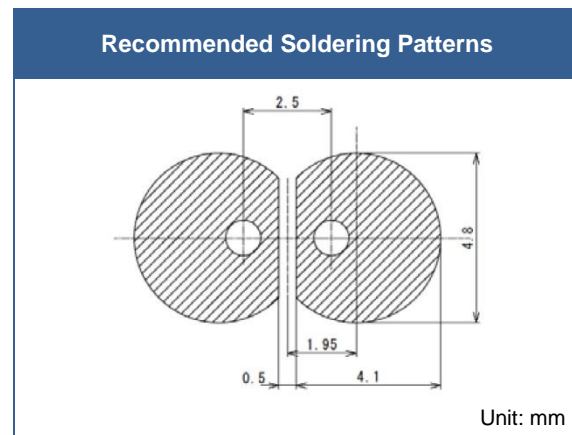
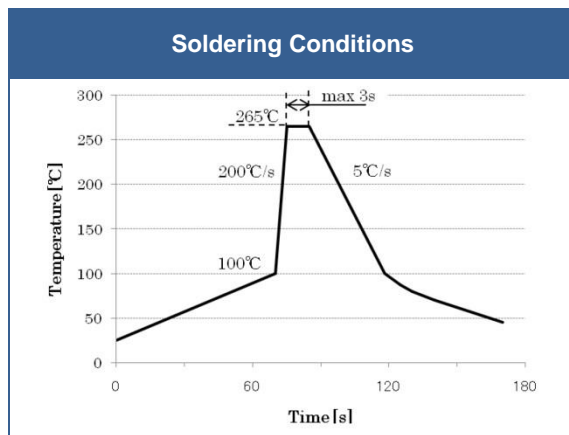

Above table specifies the maximum allowed duration and temperature during soldering. It is strongly advised to perform soldering at the shortest time and lowest temperature possible.

Cleaning:

Cleaning with isopropyl alcohol, propanol, or ethyl alcohol is recommended

DO NOT USE acetone, chloroform, trichloroethylene, or MKS

DO NOT USE ultrasonic cleaners

Static Electricity:

LEDs are sensitive to electrostatic discharge (ESD). Precautions against ESD must be taken when handling or operating these LEDs. Surge voltage or electrostatic discharge can result in complete failure of the device.

Radiation:

During operation these LEDs do emit light, which could be hazardous to skin and eyes, and may cause cancer. Do avoid exposure to the emitted light. Protective glasses if needed. It is further advised to attach a warning label on products/systems.

Operation:

Do only operate LEDs with a current source.

Running these LEDs from a voltage source will result in complete failure of the device.

Current of a LED is an exponential function of the voltage across it. Usage of current regulated drive circuits is mandatory.