



LED760-33AU

- Infrared LED
- 760 nm, 27 mW
- Chip: AlGaAs, 400 x 400 μm , 1 pc.
- 3 mm Clear Molding, Epoxy Resin
- Viewing Angle: 36°



Description



LED760-33AU contains one AlGaAs LED chip die with a typical peak wavelength of **760 nm** and radiation power of **27 mW**. It comes in $\varnothing 3$ mm clear molding package with soldered lead frame (lead free) and lens molded with epoxy resin.

Maximum Ratings ($T_{\text{CASE}}=25^{\circ}\text{C}$)

Parameter	Symbol	Values		Unit
		Min.	Max.	
Power Dissipation	P_D		220	mW
Forward Current	I_F		100	mA
Pulse Forward Current *1	I_{FP}		500	mA
Reverse Voltage	V_F		5	V
Thermal Resistance	R_{THJA}		210	K/W
Junction Temperature	T_J		120	$^{\circ}\text{C}$
Operating Temperature	T_{CASE}	- 40	+ 100	$^{\circ}\text{C}$
Storage Temperature	T_{STG}	- 40	+ 100	$^{\circ}\text{C}$
Lead Solder Temperature *2	T_{SLD}		+ 265	$^{\circ}\text{C}$

*1 duty=1%, pulse width = 10 μs

*2 must be completed within 5 seconds

Electro-Optical Characteristics ($T_{\text{CASE}}=25^{\circ}\text{C}$)

Parameter	Symbol	Conditions	Values			Unit
			Min.	Typ.	Max.	
Peak Wavelength	λ_P	$I_F=50\text{mA}$	750		770	nm
Half Width	$\Delta\lambda$	$I_F=50\text{mA}$		26		nm
Forward Voltage	V_F	$I_F=50\text{mA}$		1.8	2.2	V
	V_{FP}	$I_{FP}=500\text{mA}$		4.2		
Radiated Power *1	P_O	$I_F=50\text{mA}$		27		mW
		$I_{FP}=500\text{mA}$		250		
Radiant Intensity *2	I_E	$I_F=50\text{mA}$		130		mW/sr
		$I_{FP}=500\text{mA}$		1200		
Viewing Angle	$2\theta_{1/2}$	$I_F=50\text{mA}$		36		deg.
Rise Time	t_r	$I_F=50\text{mA}$		10		ns
Fall Time	t_f	$I_F=50\text{mA}$		15		ns

*1 measured by S3584-08

*2 measured by CIE127-2007 Condition B



Typical Performance Curves

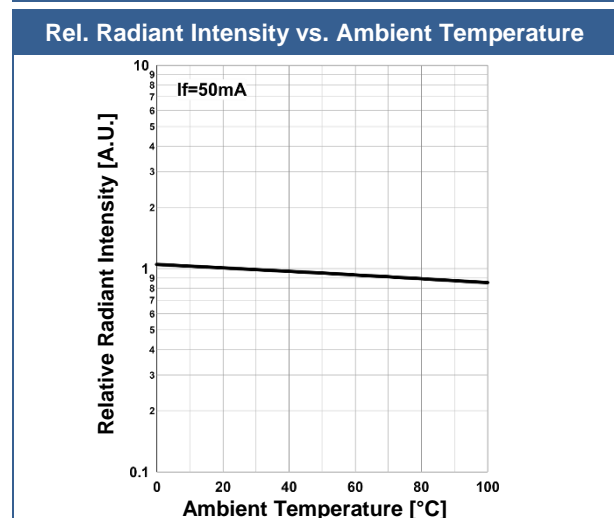
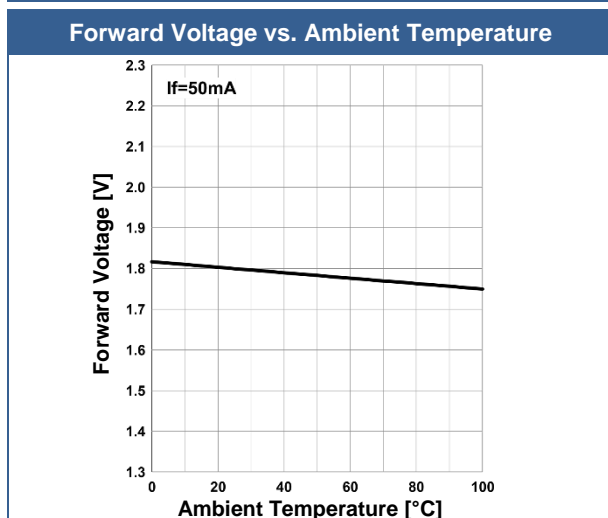
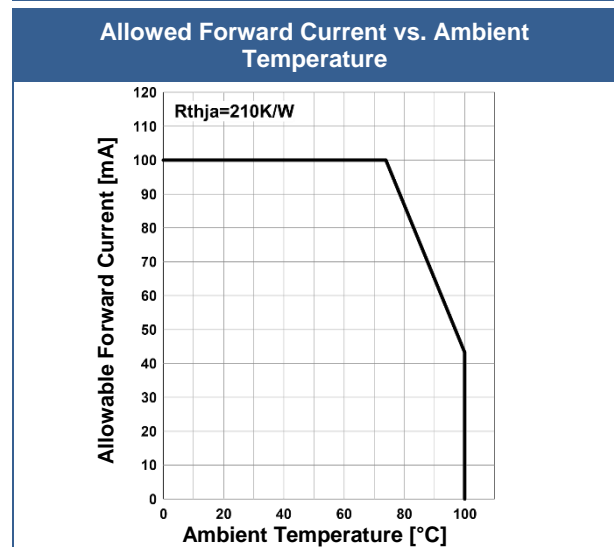
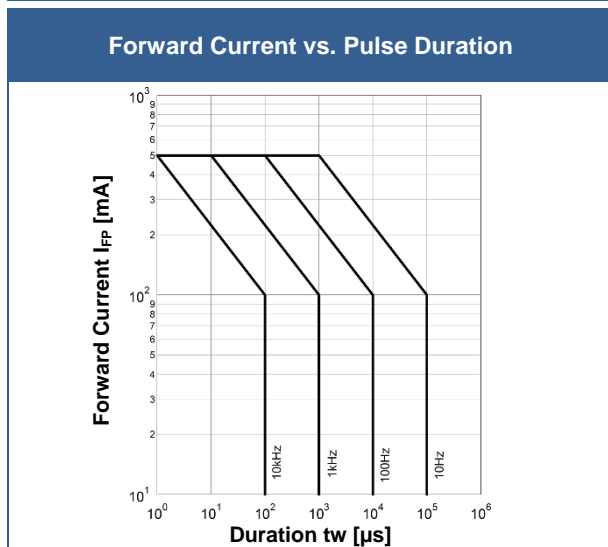
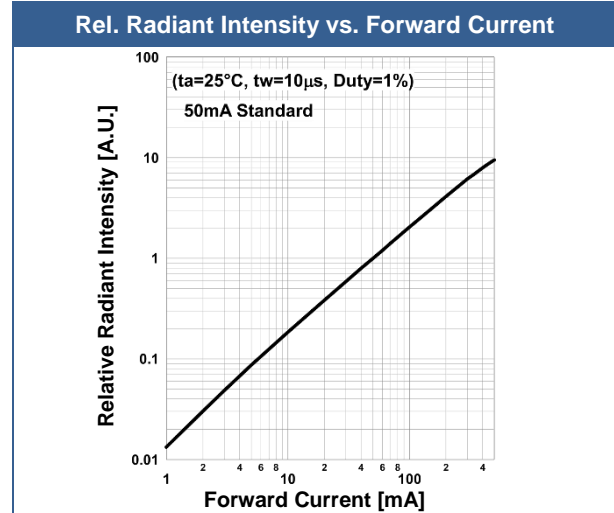
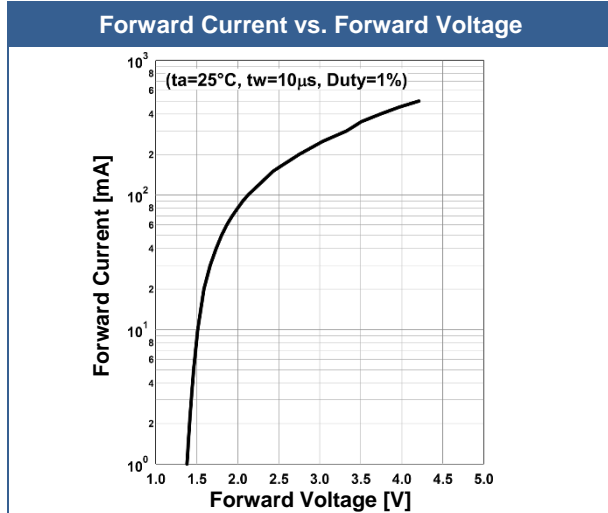

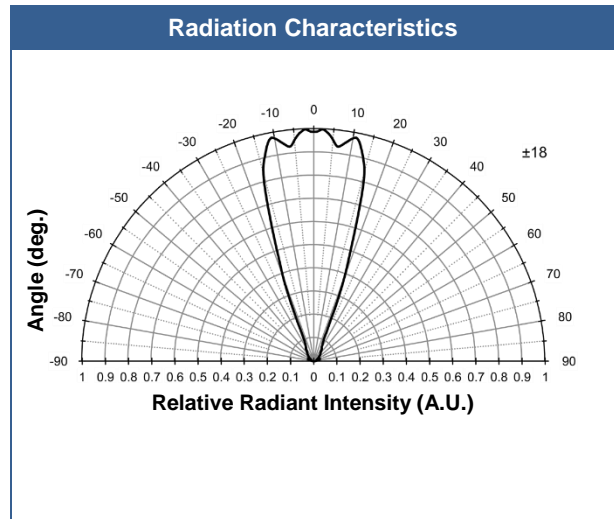
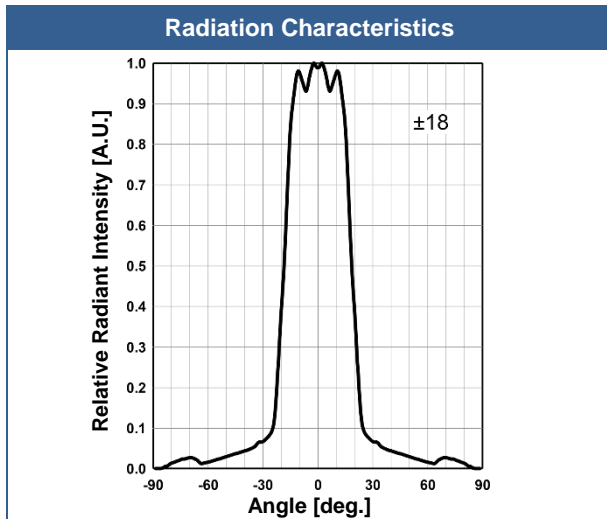
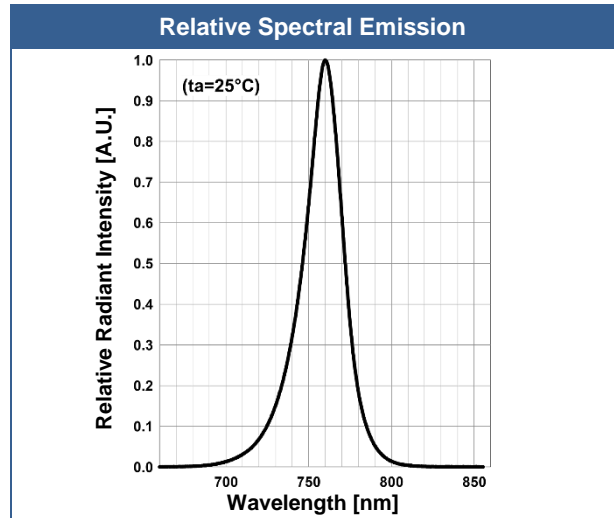
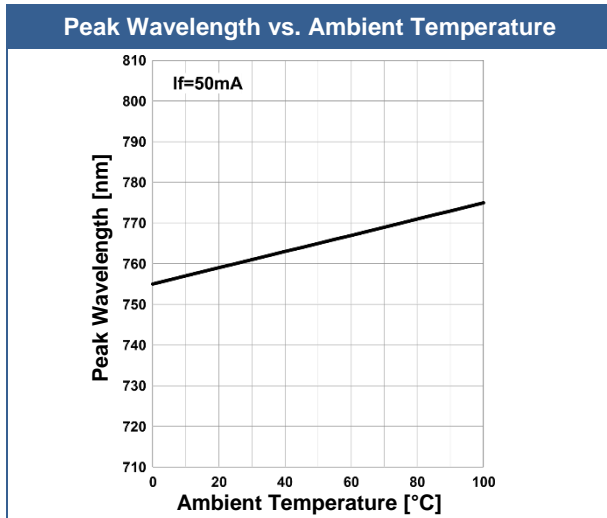

Outline Dimensions

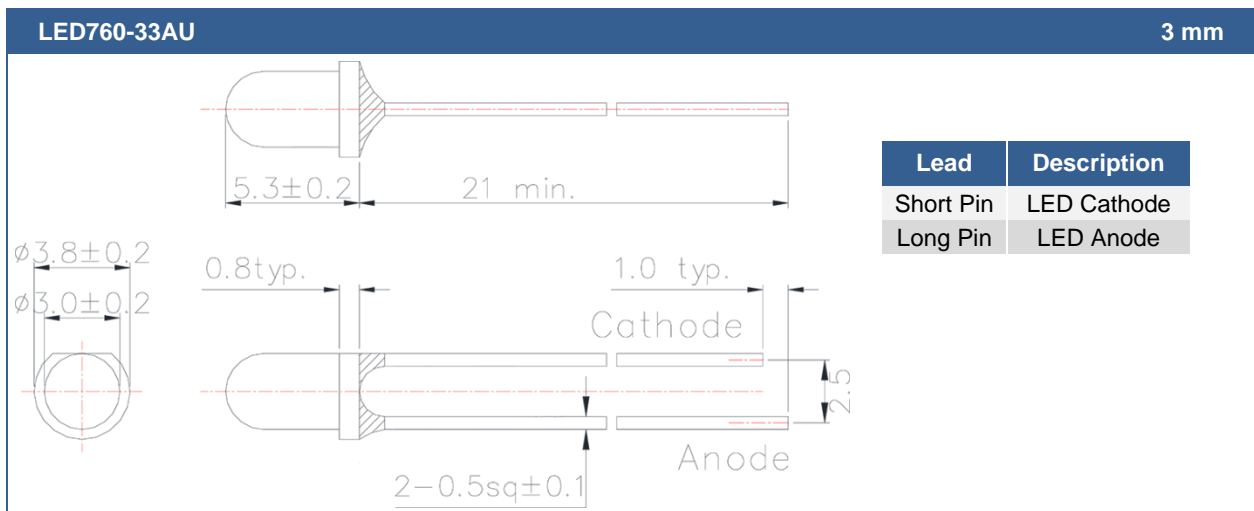

All Dimensions in mm



Precautions

Soldering:

- Do avoid overheating of the LED
- Do avoid electrostatic discharge (ESD)
- Do avoid mechanical stress, shock, and vibration
- Do only use non-corrosive flux
- Do not apply current to the LED until it has cooled down to room temperature after soldering

Recommended soldering conditions:

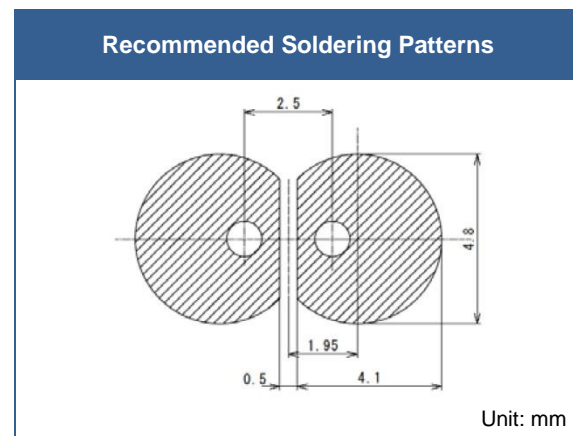
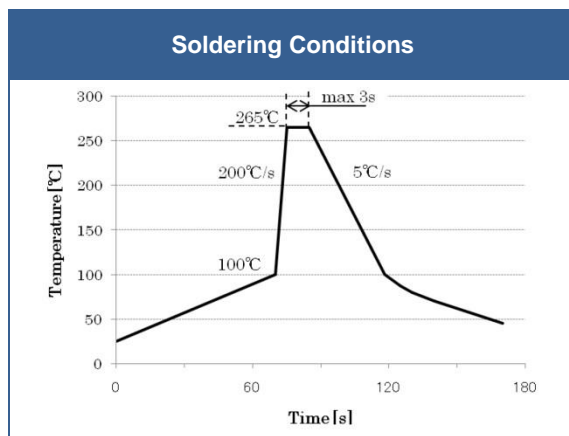

Above table specifies the maximum allowed duration and temperature during soldering. It is strongly advised to perform soldering at the shortest time and lowest temperature possible.

Cleaning:

Cleaning with isopropyl alcohol, propanol, or ethyl alcohol is recommended

DO NOT USE acetone, chloroform, trichloroethylene, or MKS

DO NOT USE ultrasonic cleaners

Static Electricity:

LEDs are sensitive to electrostatic discharge (ESD). Precautions against ESD must be taken when handling or operating these LEDs. Surge voltage or electrostatic discharge can result in complete failure of the device.

Radiation:

During operation these LEDs do emit light, which could be hazardous to skin and eyes, and may cause cancer. Do avoid exposure to the emitted light. Protective glasses if needed. It is further advised to attach a warning label on products/systems.

Operation:

Do only operate LEDs with a current source.

Running these LEDs from a voltage source will result in complete failure of the device.

Current of a LED is an exponential function of the voltage across it. Usage of current regulated drive circuits is mandatory.



Revisions History

Rel.	Rel. Date	Chapter	Modification	Page
A1	2017-03	-	Initial release	-

© All Rights Reserved

The above specifications are for reference purpose only and subjected to change without prior notice