

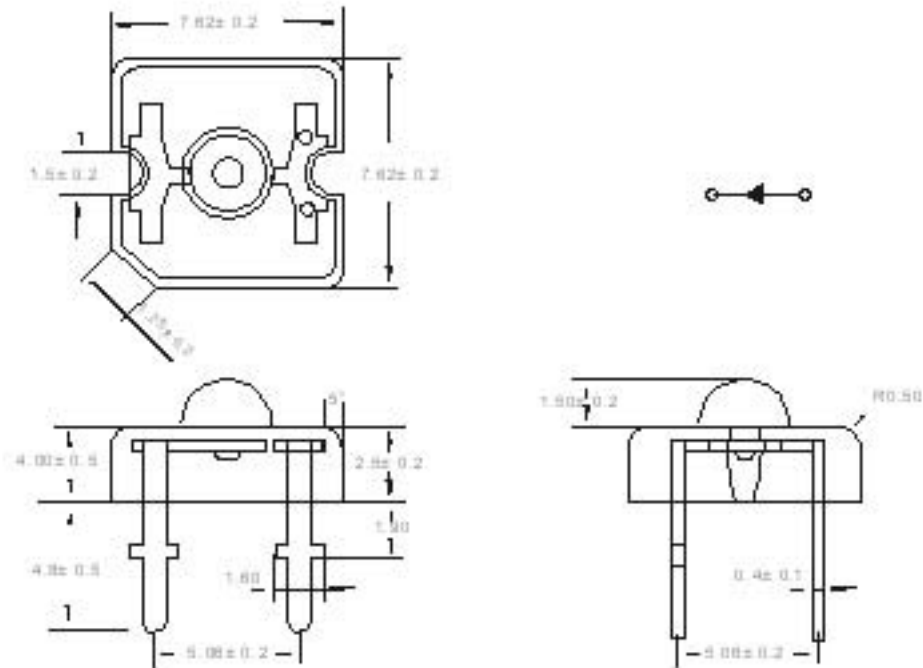

3G1S2HCA

Pack Dimensions



PRODUCT MODEL		EMITTING COLOR			MATERIAL	
3G1S2HCA		SUPER GREEN			InGaN	
Electro-Optical Characteristics (T_a = +25°C)						
PARAMETER	SYMBOL	TEST CONDITIONS	MIN	TYP.	MAX	UNIT
Forward Voltage	V _F	I _F = 20 mA	3.00	3.30	3.60	V
Reverse Current	I _R	V _R = 5 V			10	μA
Luminous intensity	I _v	I _F = 20 mA	2000	2500	3000	mcd
Chromaticity Coordinate	λ _p	I _F = 20 mA	520	522	525	nm
	Δλ	I _F = 20 mA		20		nm
Viewing Angle	Δθ	I _F = 20 mA		±45		deg
ABSOLUTE MAXIMUM RATING (T_a = +25°C)						
Reverse Voltage (V)	Continuous Forward Current (mA)	Peak forward Current (mA)	Power Dissipation (mw)	Operating Temperature Range (°C)	Storage Temperature Range (°C)	
10	100	500	200	-40~85	-40~10	