

# LED680-66-16100

## TECHNICAL DATA

### SUPER HIGH POWER RED LED

Structure: **16 power LED chips, 4 x 4 parallel array**  
 Peak Wavelength: **typ. 680 nm**  
 Optical Output Power: **typ. 450 mW cw @ 1.4 A**  
 Package: **TO-66 with silicone + epoxy resin**

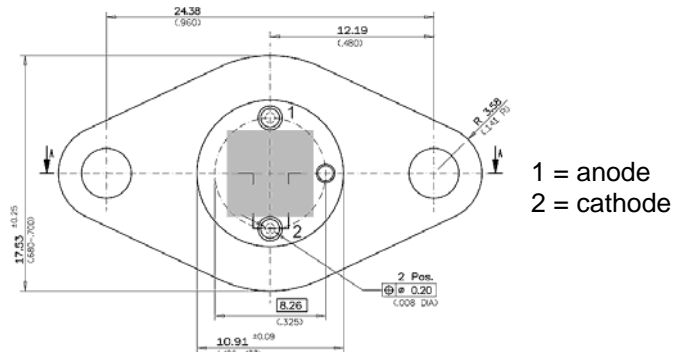

#### Absolute Maximum Ratings (Tc = 25°C)

CHARACTERISTIC	SYMBOL	RATING	UNIT
Power dissipation	P <sub>D</sub>	20	W
DC forward current **)	I <sub>F</sub>	1.8	A
Pulse forward current *)	I <sub>FP</sub>	-	A
Reverse voltage	V <sub>R</sub>	5	V
Operating lifetime	T	50.000	h
Operating case temperature	T <sub>OP</sub>	-30 .. +70	°C
Storage temperature	T <sub>STG</sub>	-60 .. +85	°C

\*) Pulse width ≤ 10 μs, f ≤ 500 Hz

#### Optical-Electrical Characteristics (Tc = 25°C)

CHARACTERISTIC	SYMBOL	TEST CONDITION	MIN	TYP	MAX	UNIT
Radiant flux	θ <sub>e</sub> (680 nm)	I <sub>F</sub> = 1.4 A	450	450	500	mW
Luminous flux	θ <sub>v</sub> (680 nm)	I <sub>F</sub> = 1.4 A	-	-	-	lm
Luminous intensity	I <sub>v</sub> (680 nm)	I <sub>F</sub> = 1.4 A	-	-	-	cd
Forward voltage	V <sub>F</sub>	I <sub>F</sub> = 1.4 A	7.2	7.7	8.3	V
Reverse current	I <sub>R</sub>	V <sub>R</sub> = 5 V			10	μA
Peak wavelength	λ <sub>P</sub>	I <sub>F</sub> = 1.4 A	670	680	690	nm
Spectrum half width	Δλ	I <sub>F</sub> = 1.4 A		30		nm
Emission angle FWHM	θ <sub>1/2</sub>	I <sub>F</sub> = 1.4 A		±60		°

#### IMPORTANT NOTE FOR SAFE OPERATION

**This high power LED must be cooled! \*\*)** Use a heat sink with a thermal resistance ≤8K/W. Maximum uncooled allowed operation current ≤80 mA. Do not view directly into the emitting area of the LED when in operation!



**ROITHNER LASERTECHNIK GmbH**

WIEDNER HAUPTSTRASSE 76, 1040 VIENNA, AUSTRIA  
 TEL: +43 -1- 586 52 43-0 FAX: +43 -1- 586 52 43-44  
 office@roithner-laser.com www.roithner-laser.com