



## LED21 series

- Mid-IR LED Series
- 2.10 – 2.19  $\mu\text{m}$
- Typ. 1.2 mW QCW



### Description

**LED21 series** contain one LED chip die with a typical peak wavelength of **2.15  $\mu\text{m}$** , an optical power of typ. **1.2 mW QCW**. There are different options of packaging available, as you can choose between TO-can, with parabolic reflector (R), window (W), and containing thermoelectric cooler and thermoresistor (T).

### Maximum Ratings

Parameter	Symbol	Values		Unit
		Min.	Max.	
Operating Current, QCW mode	$I_{QCW\ max}$		250	mA
Operating Current, pulsed mode	$I_{PULSE\ max}$		2	A
Storage Temperature *	$I_{STR}$	-60	+90	$^{\circ}\text{C}$
Operating Temperature *	$T_{CASE}$	-60	+90	$^{\circ}\text{C}$
Lead Solder Temperature * <sup>2</sup>	$T_{SLD}$		+180	$^{\circ}\text{C}$

\* Temperature range may vary for different packaging types

\*<sup>2</sup> must be completed within 5 seconds

### LED Characteristics

( $T_{CASE}=25^{\circ}\text{C}$ )

Parameter	Symbol	Conditions	Values			Unit
			Min.	Typ.	Max.	
Peak Wavelength	$\lambda_P$	$I_F=150\text{mA}$ QCW	2.10		2.19	$\mu\text{m}$
Half Width (FWHM)	$\Delta\lambda$	$I_F=150\text{mA}$ QCW	150		250	nm
Optical Output Power, QCW *	$P_O$	QCW mode *	0.8	1.2		mW
Optical Output Power, pulsed * <sup>2</sup>	$P_O$	Pulse mode * <sup>2</sup>	7.5	12		mW
Operating Voltage	$V_{OP}$	$I_F=200\text{mA}$ QCW	0.5		2.5	V
Switching Time	$t_s$					ns

\* Repetition rate: 0.5 kHz, pulse duration: 1 ms, duty cycle: 50%, current: 200 mA

\*<sup>2</sup> Repetition rate: 0.5 kHz, pulse duration: 20  $\mu\text{s}$ , duty cycle: 1%, current: 1 A

### Packages

Part Number	Package
LED21	TO-18 with cap with glass window
LED21-R	TO-18 with parabolic reflector without glass window
LED21-RW	TO-18 with parabolic reflector with glass window
LED21-TW	TO-5 with built-in thermocooler and thermoresistor, covered by cap with glass window
LED21-TRW	TO-5 with built-in thermocooler and thermoresistor, covered by parabolic reflector with glass window

All parameters refer to LEDs in TO18 package with a cavity and operation at ambient temperature 25 $^{\circ}\text{C}$  unless otherwise stated.



## Performance Characteristics

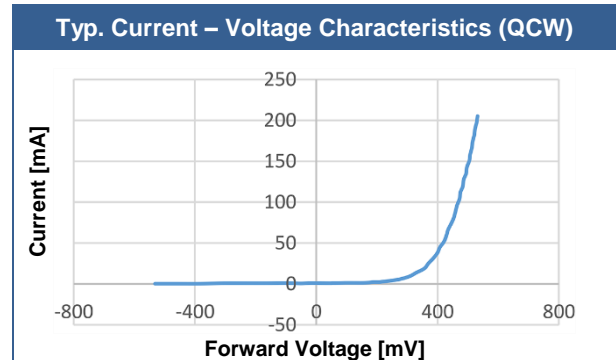
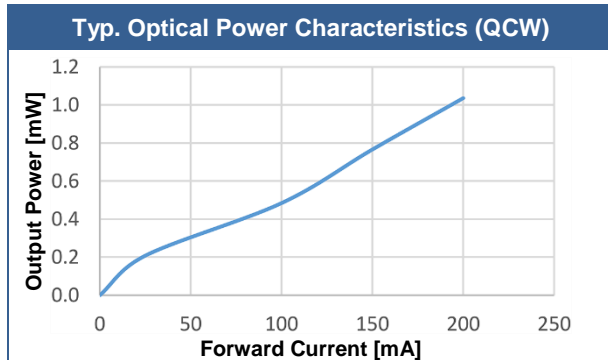
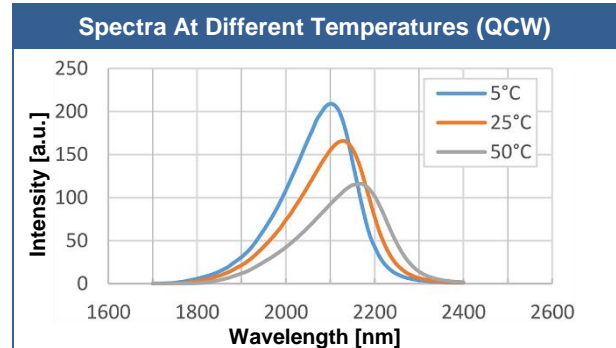
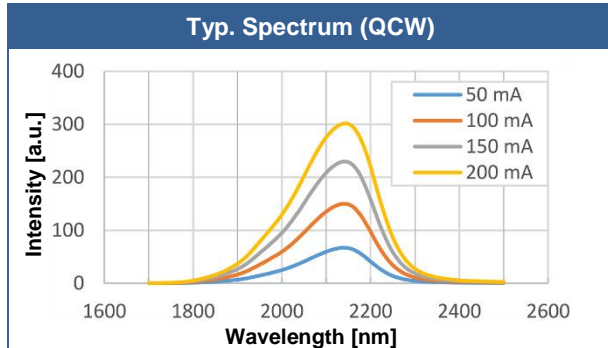

## Radiant Characteristics (Far-Field Pattern)

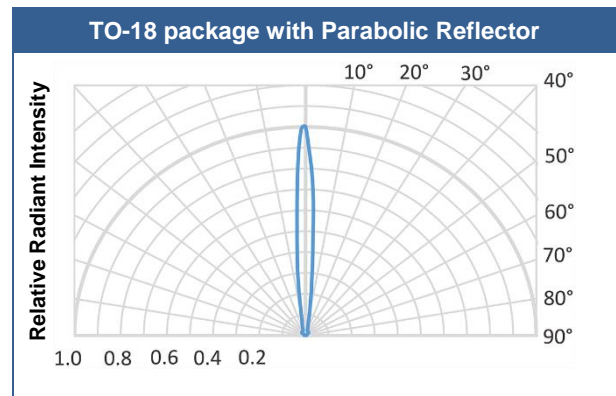
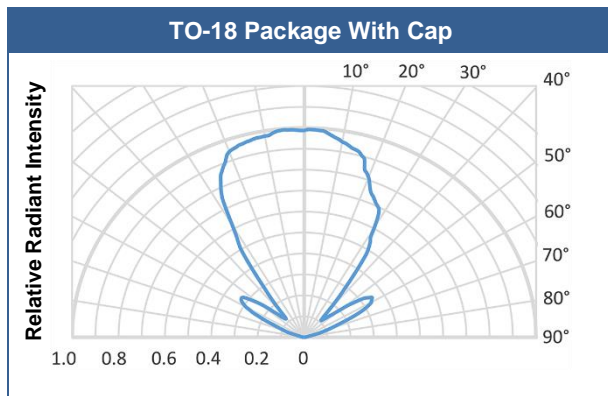



## Outline Dimensions

LED21

TO-18, with cap, with window

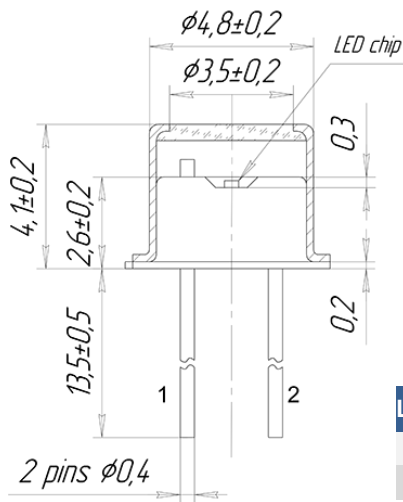

TOP VIEW

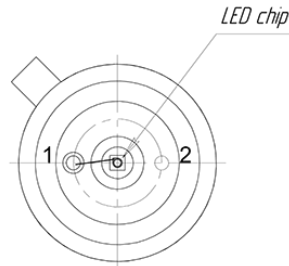

BOTTOM VIEW

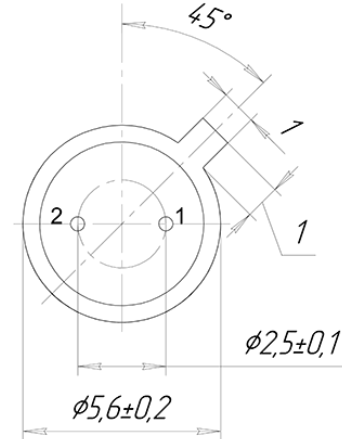

Lead	Description
PIN 1	LED Cathode
PIN 2	LED Anode (red dot)

All Dimensions in mm

LED21-R

TO-18, with parabolic reflector, without window

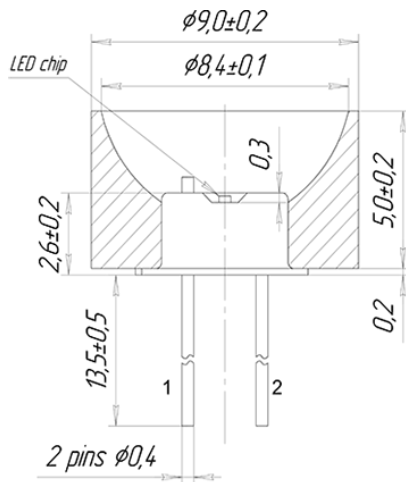

TOP VIEW

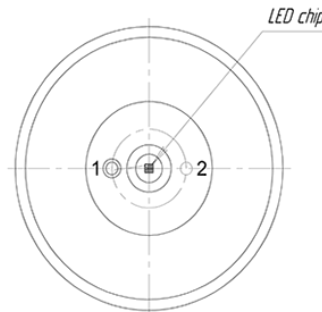

BOTTOM VIEW

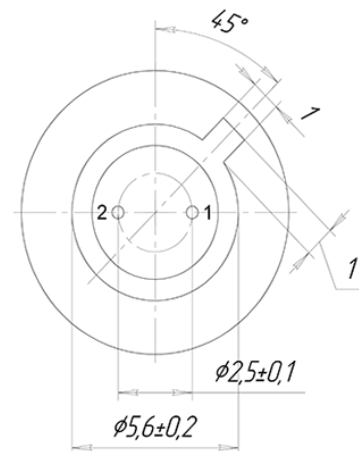

Lead	Description
PIN 1	LED Cathode
PIN 2	LED Anode (red dot)

All Dimensions in mm



## LED21-RW TO-18, with parabolic reflector and window

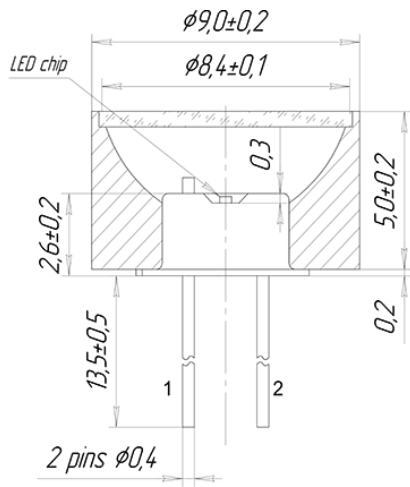

TOP VIEW

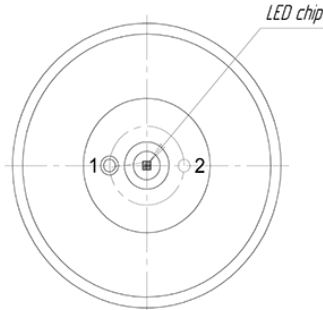

BOTTOM VIEW

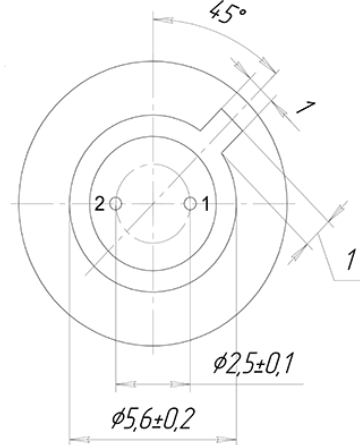

Lead	Description
PIN 1	LED Cathode
PIN 2	LED Anode (red dot)

All Dimensions in mm

## LED21-TW TO-5, thermocooler and thermoresistor, cap and window

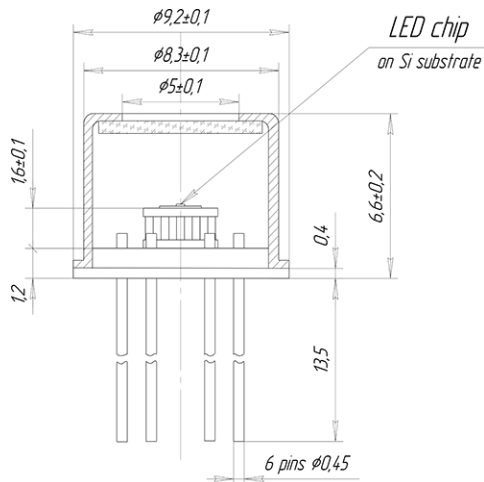

TOP VIEW

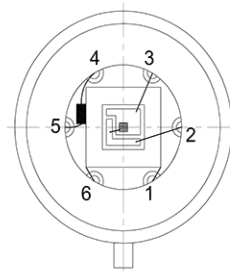

BOTTOM VIEW

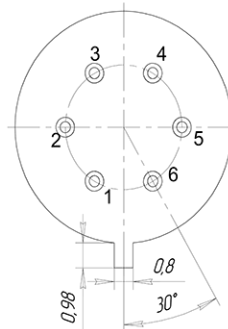

Lead	Description
PIN 1	TEC +
PIN 2	LED Anode (red dot)
PIN 3	LED Cathode
PIN 4	Thermistor
PIN 5	Thermistor
PIN 6	TEC -

All Dimensions in mm

## LED21-TRW TO-5, thermocooler and thermoresistor, cap and window

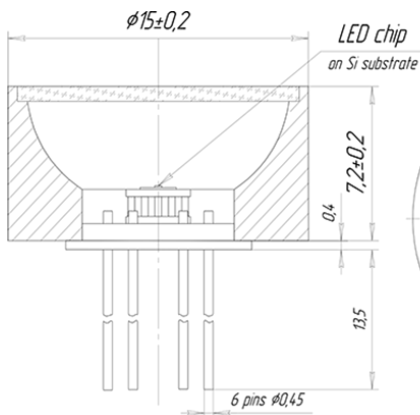

TOP VIEW

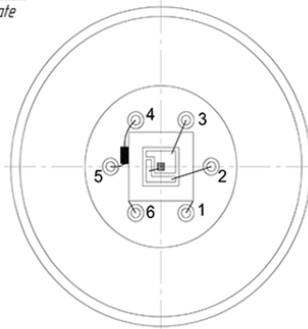

BOTTOM VIEW

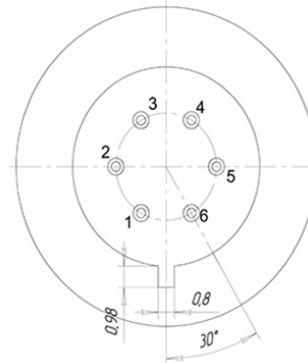

Lead	Description
PIN 1	TEC +
PIN 2	LED Anode (red dot)
PIN 3	LED Cathode
PIN 4	Thermistor
PIN 5	Thermistor
PIN 6	TEC -

All Dimensions in mm



## Operating Regime

### LED Basic Circuit Connection

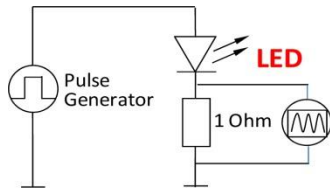

### LED With Thermoelectric Module

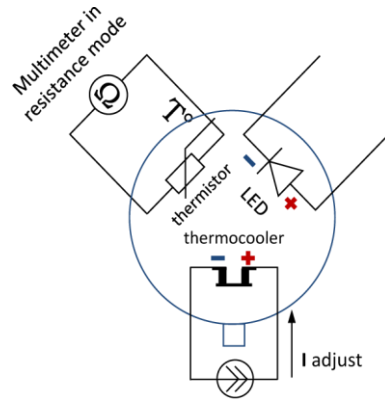

Constant current source

We recommend to use **Quasi Continuous Wave (QCW) mode** with duty cycle 50% or 25% to obtain maximum average optical power and **Pulse mode** to obtain maximum peak power. Hard CW (continuous wave) mode is **NOT** recommended.

### Quasi Continuous Wave (QCW) mode

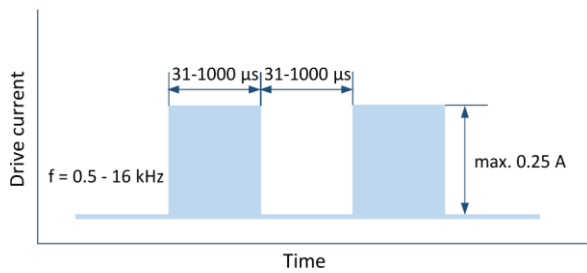

### Pulse Mode

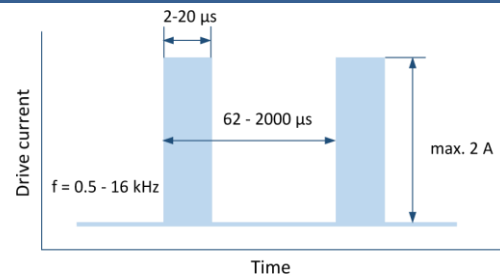



## Precautions

---

### Cautions:

- Check your connection circuits before turning on the LED.
- Mind the LED polarity: LED anode is marked with a RED dot.  
Reverse voltage applying is FORBIDDEN!
- DO NOT connect the LED to the multimeter.
- Control the current applied to the LED in order not to exceed the maximum allowable values.

### Soldering:

- Do avoid overheating of the LED
- Do avoid electrostatic discharge (ESD)
- Do avoid mechanical stress, shock, and vibration
- Do only use non-corrosive flux
- Do not apply current to the LED until it has cooled down to room temperature after soldering

### Static Electricity:

LEDs are **sensitive to electrostatic discharge (ESD)**. Precautions against ESD must be taken when handling or operating these LEDs. Surge voltage or electrostatic discharge can result in complete failure of the device.



### Operation:

Do only operate LEDs with a current source.

Running these LEDs from a voltage source will result in complete failure of the device.

Current of a LED is an exponential function of the voltage across it. Usage of current regulated drive circuits is mandatory.



## Revisions History

---

Rev.	Rel. Date	Chapter	Modification	Page
A1	2016-11-30	-	Initial release	-

---

© All Rights Reserved

The above specifications are for reference purpose only and subjected to change without prior notice