



LED22 series

- Mid-IR LED Series
- 2.20 – 2.29 μm
- 0.8 – 1.2 mW QCW



Description

LED22 series are fabricated from narrow band-gap GaInAsSb/AlGaAsSb heterostructures lattice matched to GaSb substrate. This Mid-IR LEDs provide a typical peak wavelength of **2.22 μm** , an optical power of typ. **1 mW QCW**. There are different options of packaging available, as you can choose between TO-can, with parabolic reflector (R), window (W), and containing thermoelectric cooler and thermoresistor (T).

Maximum Ratings

Parameter	Symbol	Values		Unit
		Min.	Max.	
Operating Current, QCW mode	$I_{QCW\ max}$		250	mA
Operating Current, pulsed mode	$I_{PULSE\ max}$		2	A
Storage Temperature *	I_{STR}	-60	+90	$^{\circ}\text{C}$
Operating Temperature *	T_{CASE}	-60	+90	$^{\circ}\text{C}$
Lead Solder Temperature *2	T_{SLD}		+180	$^{\circ}\text{C}$

* Temperature range may vary for different packaging types

*2 must be completed within 5 seconds

LED Characteristics

($T_{CASE}=25^{\circ}\text{C}$)

Parameter	Symbol	Conditions	Values			Unit
			Min.	Typ.	Max.	
Peak Wavelength	λ_P	$I_F=150\text{mA}$ QCW	2.20		2.29	μm
Half Width (FWHM)	$\Delta\lambda$	$I_F=150\text{mA}$ QCW	150		250	nm
Optical Output Power, QCW *	P_O	QCW mode *	0.8	1.0		mW
Optical Output Power, pulsed *2	P_O	Pulse mode *2	7.5	9.0		mW
Operating Voltage	V_{OP}	$I_F=200\text{mA}$ QCW	0.5		2.8	V
Switching Time	t_s					ns

* Repetition rate: 0.5 kHz, pulse duration: 1 ms, duty cycle: 50%, current: 200 mA

*2 Repetition rate: 0.5 kHz, pulse duration: 20 μs , duty cycle: 1%, current: 1 A

Packages

Part Number	Package
LED22	TO-18 with cap without glass window
LED22-R	TO-18 with parabolic reflector without glass window
LED22-RW	TO-18 with parabolic reflector with glass window
LED22-TW	TO-5 with built-in thermocooler and thermoresistor, covered by cap with glass window
LED22-TRW	TO-5 with built-in thermocooler and thermoresistor, covered by parabolic reflector with glass window

All parameters refer to LEDs in TO18 package with a cavity and operation at ambient temperature 25 $^{\circ}\text{C}$ unless otherwise stated.



Performance Characteristics

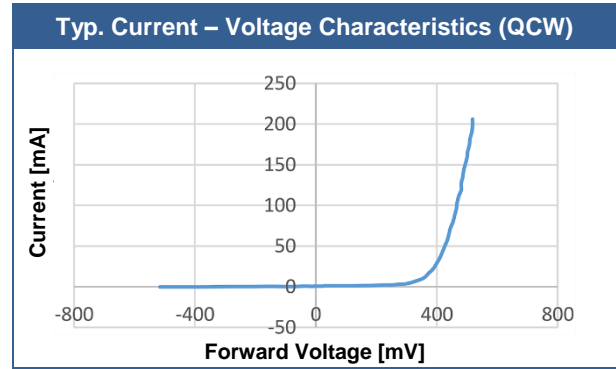
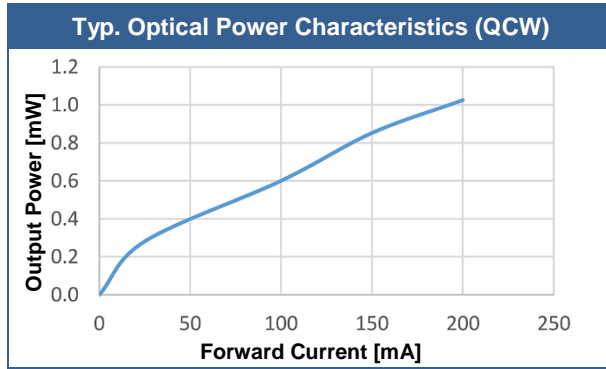
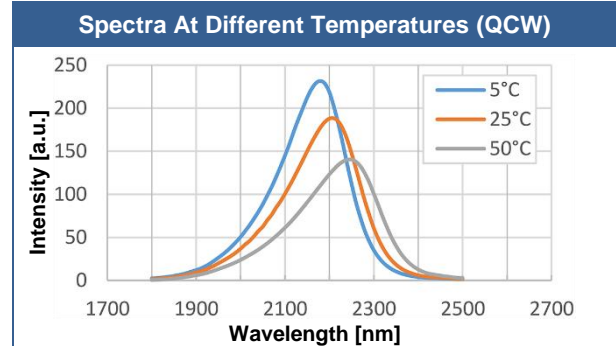
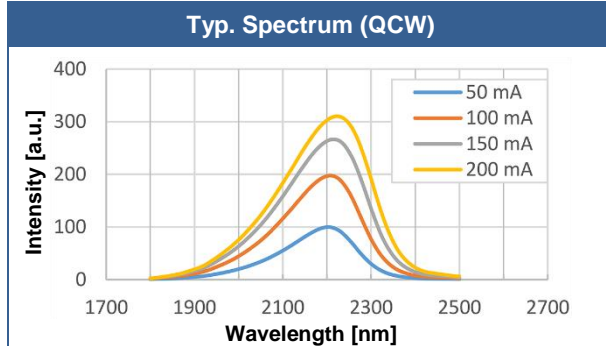

Radiant Characteristics (Far-Field Pattern)

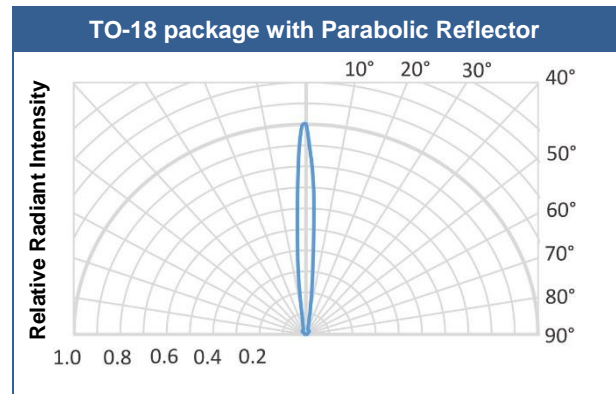
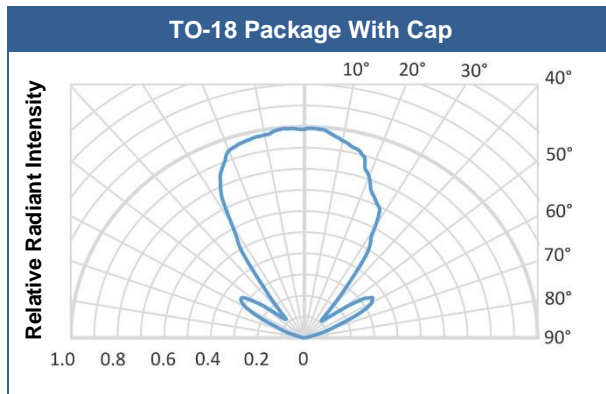



Outline Dimensions

LED22

TO-18, with cap, without window

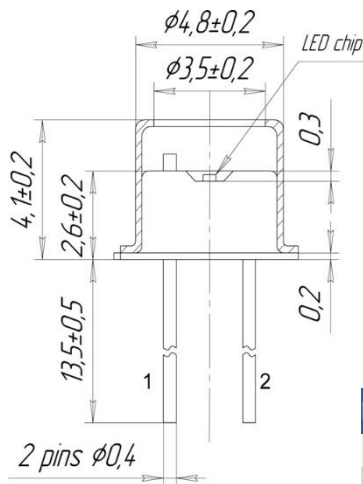

TOP VIEW

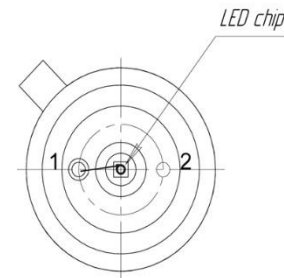

BOTTOM VIEW

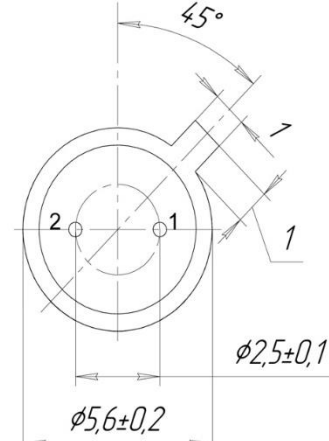

Lead	Description
PIN 1	LED Cathode
PIN 2	LED Anode (red dot)

All Dimensions in mm

LED22-R

TO-18, with parabolic reflector, without window

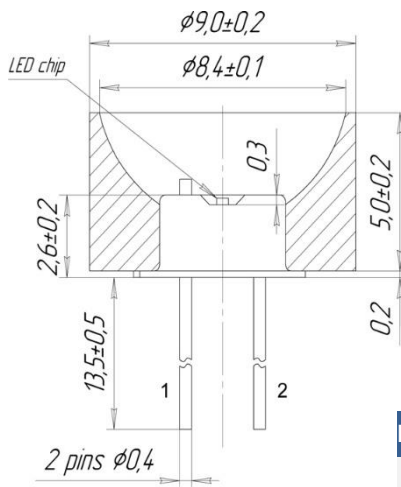

TOP VIEW

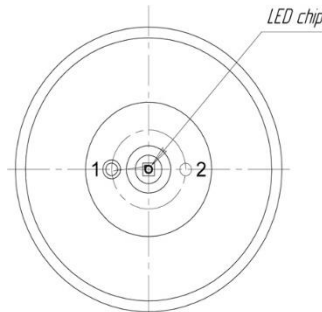

BOTTOM VIEW

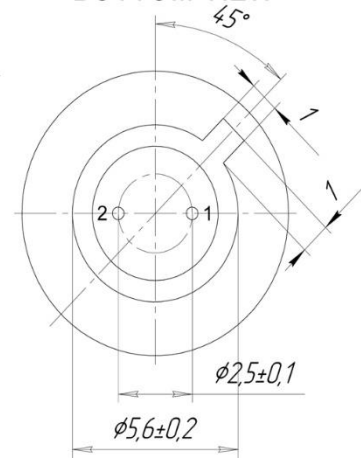

Lead	Description
PIN 1	LED Cathode
PIN 2	LED Anode (red dot)

All Dimensions in mm



LED22-RW

TO-18, with parabolic reflector and window

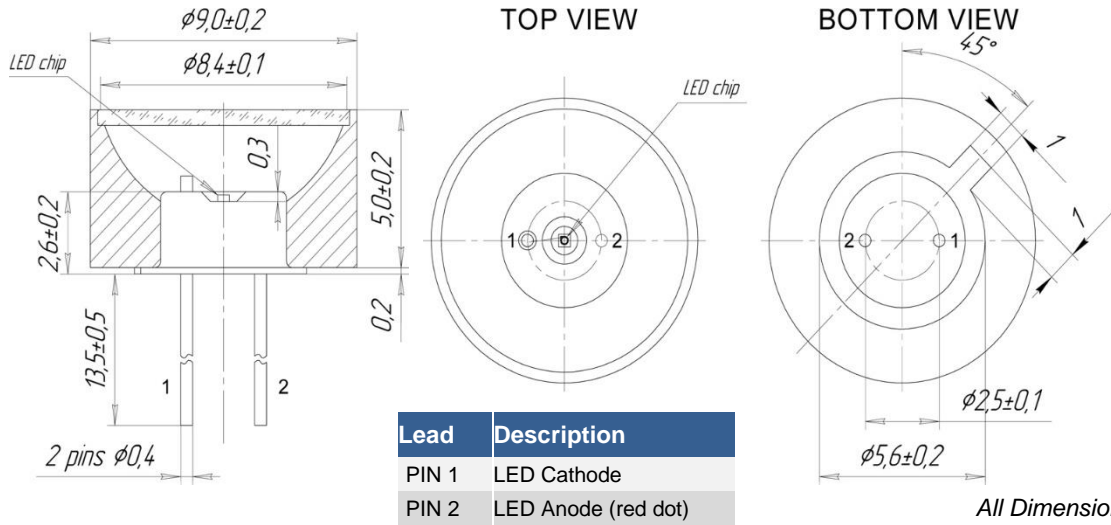

LED22-TW

TO-5, thermocooler and thermoresistor, cap and window

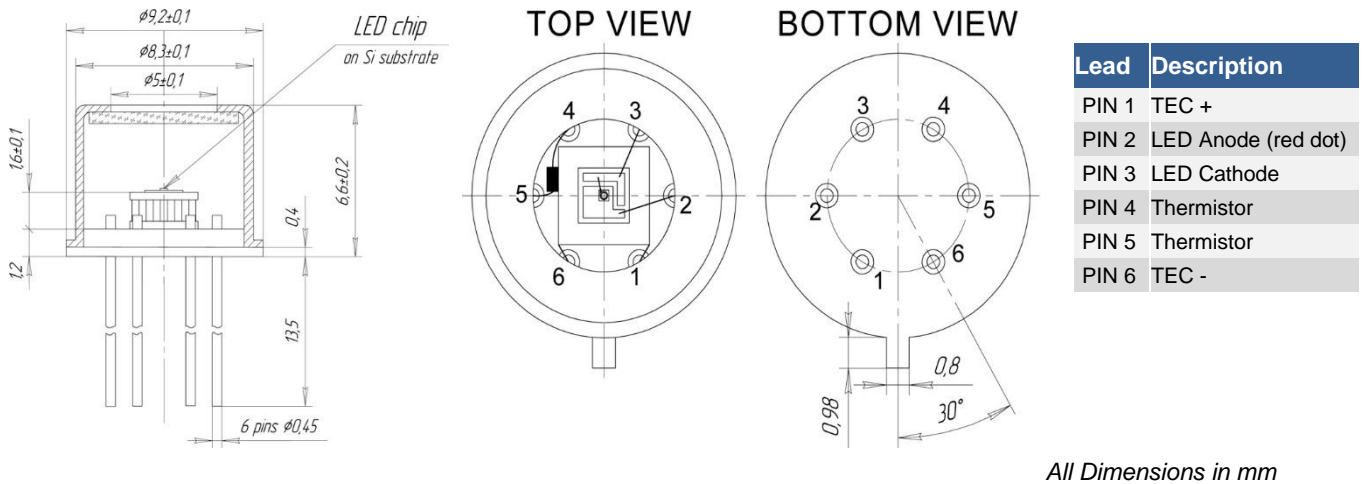

LED22-TRW

TO-5, thermocooler and thermoresistor, cap and window

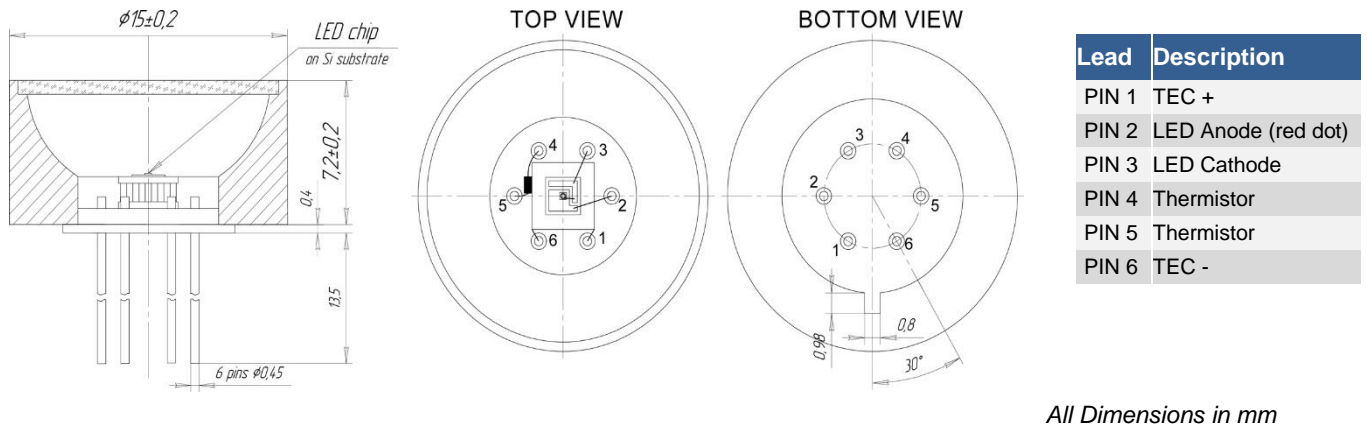



Operating Regime

LED Basic Circuit Connection

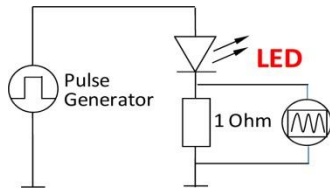

LED With Thermoelectric Module

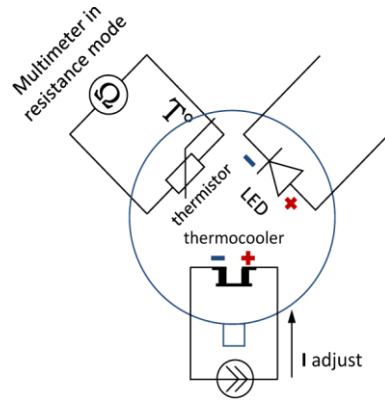

Constant current source

We recommend to use **Quasi Continuous Wave (QCW) mode** with duty cycle 50% or 25% to obtain maximum average optical power and **Pulse mode** to obtain maximum peak power. Hard CW (continuous wave) mode is **NOT** recommended.

Quasi Continuous Wave (QCW) mode

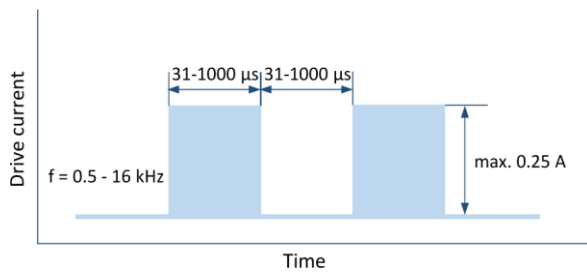

Pulse Mode

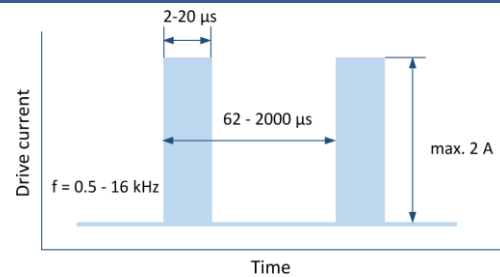



Precautions

Cautions:

- Check your connection circuits before turning on the LED.
- Mind the LED polarity: LED anode is marked with a RED dot.
Reverse voltage applying is FORBIDDEN!
- DO NOT connect the LED to the multimeter.
- Control the current applied to the LED in order not to exceed the maximum allowable values.

Soldering:

- Do avoid overheating of the LED
- Do avoid electrostatic discharge (ESD)
- Do avoid mechanical stress, shock, and vibration
- Do only use non-corrosive flux
- Do not apply current to the LED until it has cooled down to room temperature after soldering

Static Electricity:

LEDs are **sensitive to electrostatic discharge (ESD)**. Precautions against ESD must be taken when handling or operating these LEDs. Surge voltage or electrostatic discharge can result in complete failure of the device.



Operation:

Do only operate LEDs with a current source.

Running these LEDs from a voltage source will result in complete failure of the device.

Current of a LED is an exponential function of the voltage across it. Usage of current regulated drive circuits is mandatory.



Revisions History

Rev.	Rel. Date	Chapter	Modification	Page
A1	2020-06-17	-	Initial release	-

© All Rights Reserved

The above specifications are for reference purpose only and subjected to change without prior notice