



PD25-10 series

- Mid-IR PD Series
- Max. Sensitivity: 1.65 – 2.35 μm
- Sensitive Area Diameter: \varnothing 1.0 mm



Description

PD25-10 series are fabricated from narrow band-gap GaInAsSb/AlGaAsSb-based heterostructures lattice matched to GaSb substrate. The maximum sensitivity wavelength is specified with 1.65 – 2.35 μm and a cut-off wavelength at 2.5 μm . The photodiode chip has a photosensitive area of \varnothing 1.0 mm and can be mounted into different options of packages. You can choose between TO-can, with additional parabolic reflector (R), window (W), containing thermoelectric cooler and thermoresistor (T), and as aluminum tube with built-in preamplifier.

Maximum Ratings

| Parameter | Symbol | Values | | Unit |
|----------------------------|------------|--------|-------|--------------------|
| | | Min. | Max. | |
| Operating Temperature *1 | T_{CASE} | -60 | + 90 | $^{\circ}\text{C}$ |
| Storage Temperature *1 | T_{STG} | -60 | + 90 | $^{\circ}\text{C}$ |
| Lead Solder Temperature *2 | T_{SLD} | | + 180 | $^{\circ}\text{C}$ |

*1 Temperature range may vary for different packaging types.

*2 must be completed within 5 seconds

Photodiode Characteristics ($T_{CASE}=25^{\circ}\text{C}$)

| Parameter | Symbol | Conditions | Values | | | Unit |
|--------------------------------------|-----------------|--------------------------|---------------------|----------------------|----------------------|--|
| | | | Min. | Typ. | Max. | |
| Sensitive Area Diameter | D | | | 1.0 | | mm |
| Cut-off Wavelength (at 10%) | λ_{cut} | | | 2.5 | | μm |
| Max. Sensitivity Wavelength (at 80%) | λ_P | | 1.65 | | 2.35 | μm |
| Reverse Voltage | V_R | | | | 1 | V |
| Dark Current | I_D | $V_R=1\text{V}$ | | 15 | 22 | μA |
| Shunt Resistance | R_{SH} | $V_R=10\text{mV}$ | 8 | 15 | | k Ω |
| Capacitance | C | $V_R=10\text{mV}$ | | 1000 | 1100 | pF |
| Sensitivity | S | $\lambda=2.2\mu\text{m}$ | 1.0 | 1.1 | | A/W |
| Noise Equivalent Power | NEP | $\lambda=2.2\mu\text{m}$ | | $9.5 \cdot 10^{-13}$ | $1.4 \cdot 10^{-12}$ | $\text{W}/\sqrt{\text{Hz}}$ |
| Detectivity | D^* | $\lambda=2.2\mu\text{m}$ | $6.2 \cdot 10^{10}$ | $9.3 \cdot 10^{10}$ | | $\text{cm} \cdot \sqrt{\text{Hz}} \cdot \text{W}^{-1}$ |

Package Options

| Part Number | Description |
|---------------|--|
| PD25-10 | TO-18 with cap without glass window |
| PD25-10R | TO-18 with parabolic reflector without glass window |
| PD25-10RW | TO-18 with parabolic reflector with glass window |
| PD25-10TW | TO-5 with built-in thermocooler and thermoresistor, covered by cap with glass window |
| PD25-10TRW | TO-5 with built-in thermocooler and thermoresistor, covered by parabolic reflector with glass window |
| PD25-10R-AMP | PD with built-in preamplifier; TO-18 with parabolic reflector without window in an aluminum tube |
| PD25-10RW-AMP | PD with built-in preamplifier; TO-18 with parabolic reflector with window in an aluminum tube |



Performance Characteristics

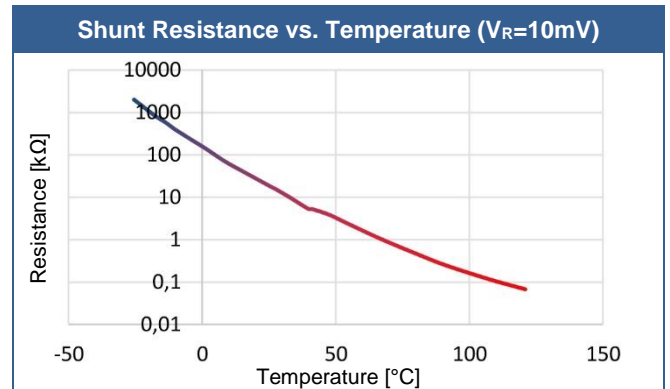
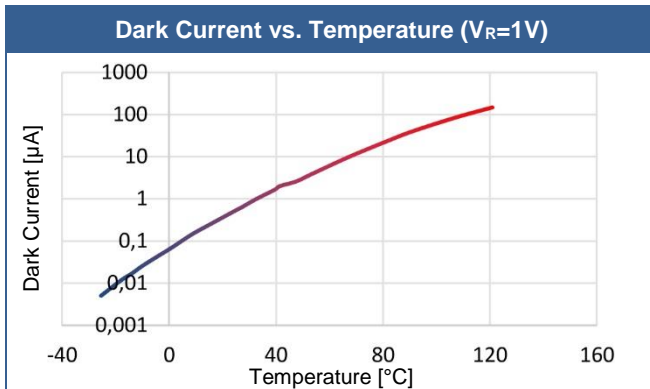
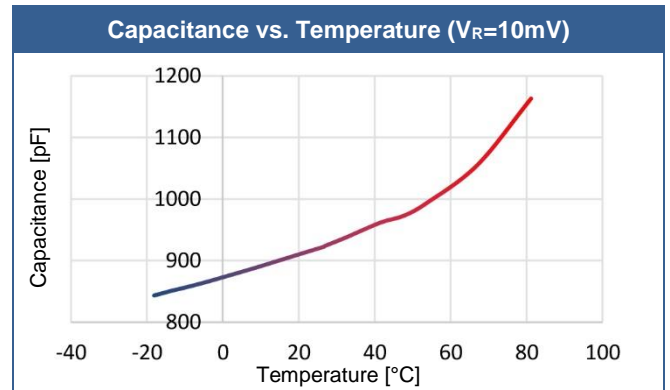
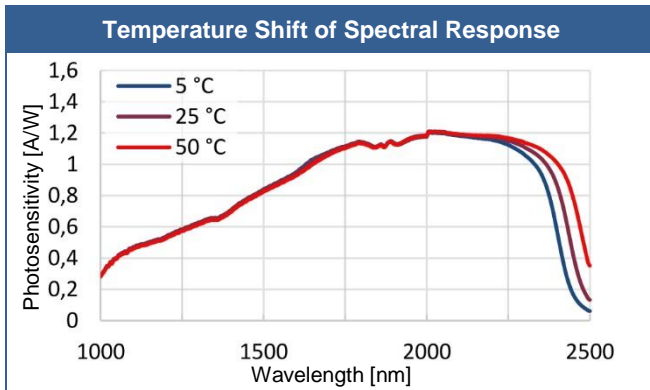
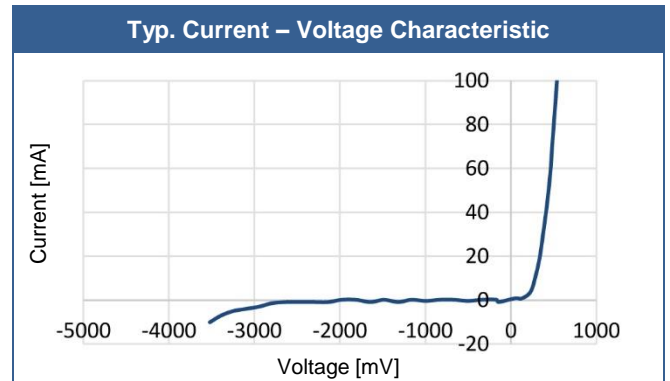
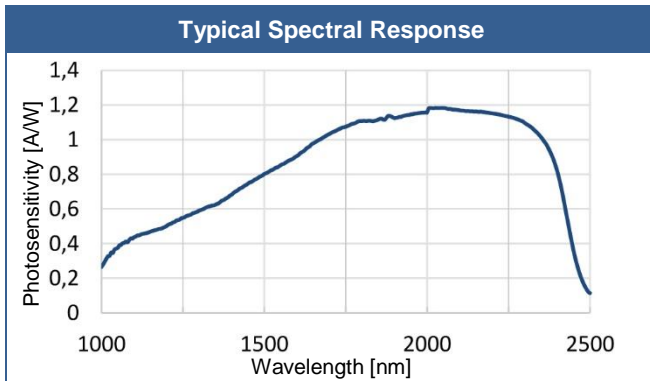



Recommended Modes of Photodiode Operation

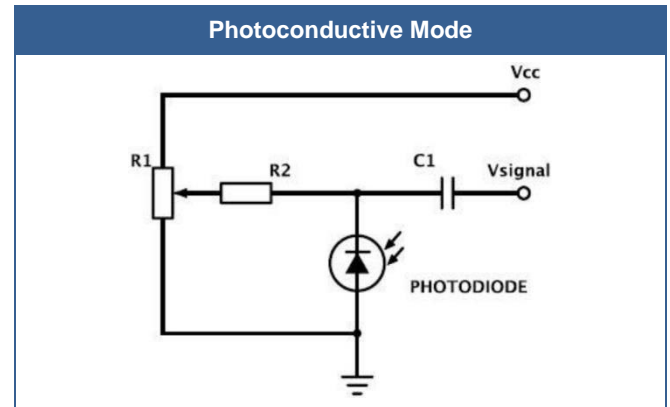
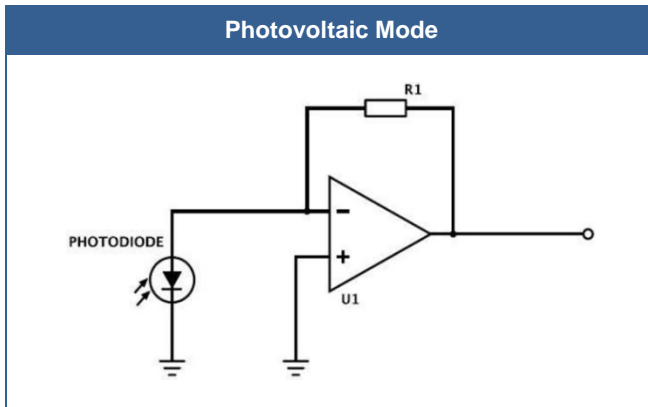

We recommend using **photovoltaic mode**, when PD is used under reverse bias.
Use Photoconductive mode (mode with reverse bias) with caution!

Important Cautions:

- Check your connection circuits before turning on the PD.
- Mind the PD polarity: PD anode is marked with a RED dot.
- DO NOT connect the PD to the multimeter.

Outline Dimensions

PD25-10

TO-18 with cap without glass window

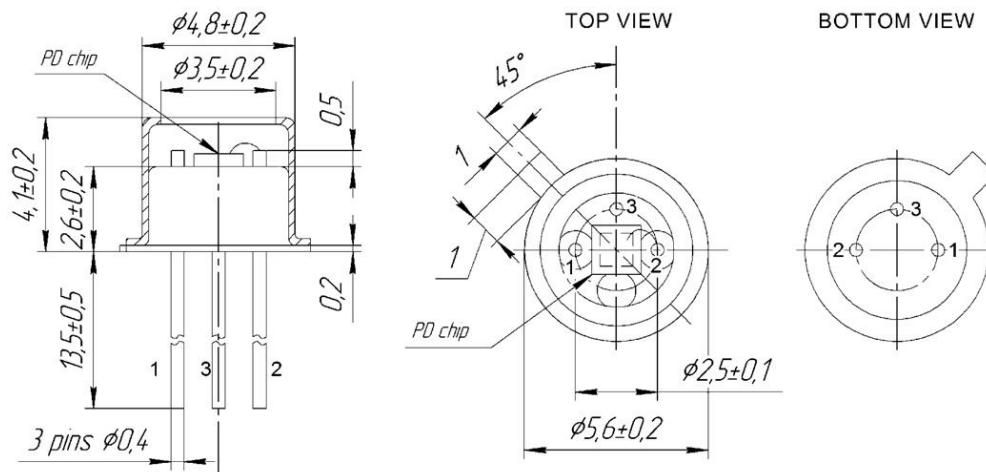

| Lead | Description |
|-------|-------------|
| PIN 1 | - |
| PIN 2 | PD Anode |
| PIN 3 | PD Cathode |

All Dimensions in mm



PD25-10R

TO-18 with parabolic reflector without glass window

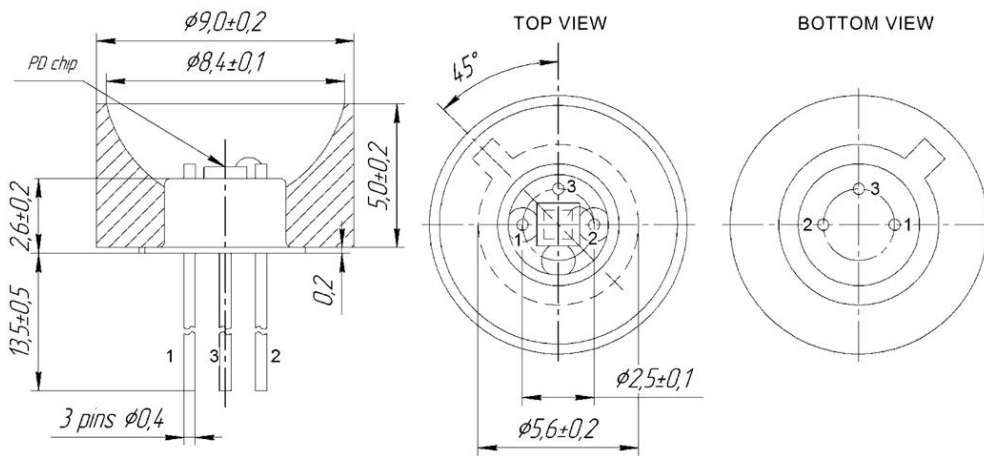

| Lead | Description |
|-------|-------------|
| PIN 1 | - |
| PIN 2 | PD Anode |
| PIN 3 | PD Cathode |

All Dimensions in mm

PD25-10RW

TO-18 with parabolic reflector with glass window

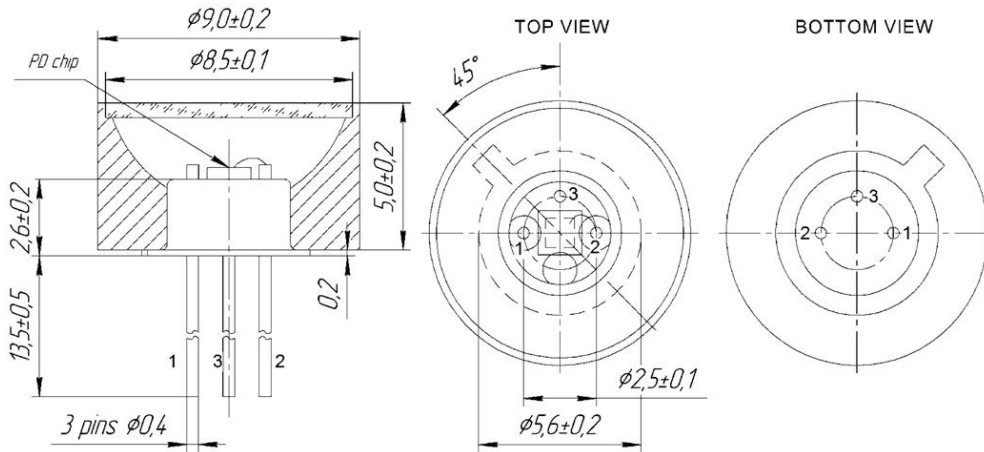

| Lead | Description |
|-------|-------------|
| PIN 1 | - |
| PIN 2 | PD Anode |
| PIN 3 | PD Cathode |

All Dimensions in mm

PD25-10TW

TO-5 with built-in thermocooler and thermoresistor, covered by cap with glass window

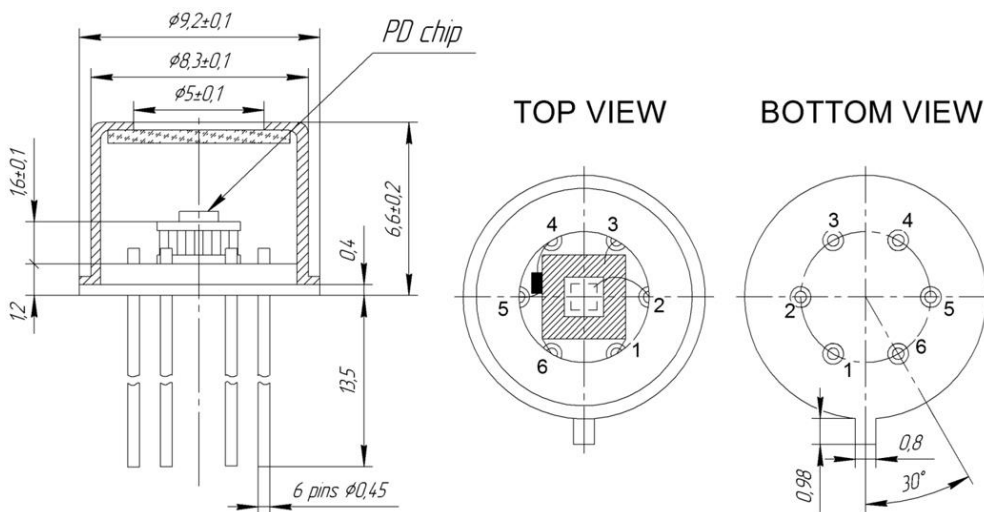

| Lead | Description |
|-------|-------------|
| PIN 1 | TEC + |
| PIN 2 | PD Anode |
| PIN 3 | PD Cathode |
| PIN 4 | Thermistor |
| PIN 5 | Thermistor |
| PIN 6 | TEC - |

All Dimensions in mm



PD25-10TRW

TO-5 with built-in thermocooler and thermoresistor, covered by parabolic reflector with glass window

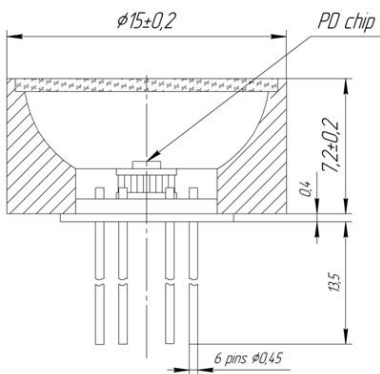

TOP VIEW

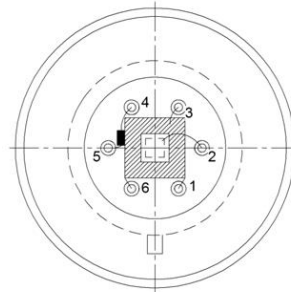

BOTTOM VIEW

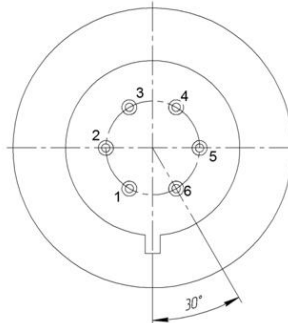

| Lead | Description |
|-------|-------------|
| PIN 1 | TEC + |
| PIN 2 | PD Anode |
| PIN 3 | PD Cathode |
| PIN 4 | Thermistor |
| PIN 5 | Thermistor |
| PIN 6 | TEC - |

All Dimensions in mm

PD25-10R-AMP

PD with built-in preamplifier; TO-18 with parabolic reflector without window in an aluminum tube

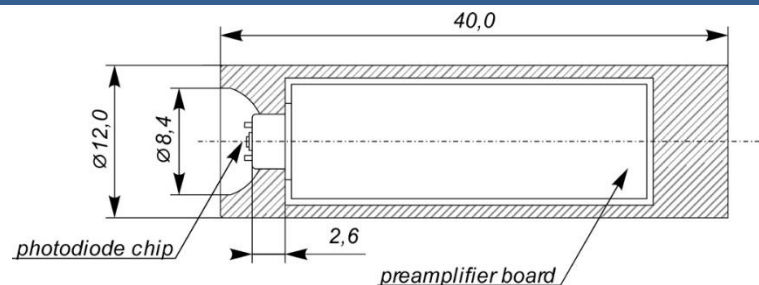

All Dimensions in mm

Power input voltage: +5 V, stabilized

Connections:

The output of PD with a built-in preamplifier has four wires:

- "+" power input (to the "+5V" of the power output terminal block of the synchronous detector);
- "ground" power input (to the "0V" of the power output terminal block of the synchronous detector);
- "ground" output photodiode signal (to the "0V" of the signal input terminal block of the synchronous detector);
- "+" output photodiode signal (to the "IN" of the signal input terminal block of the synchronous detector).

For the proper connection mind the colors of the wires pointed in the technical data provided with the photodiode.

PD25-10RW-AMP

PD with built-in preamplifier; TO-18 with parabolic reflector with window in an aluminum tube

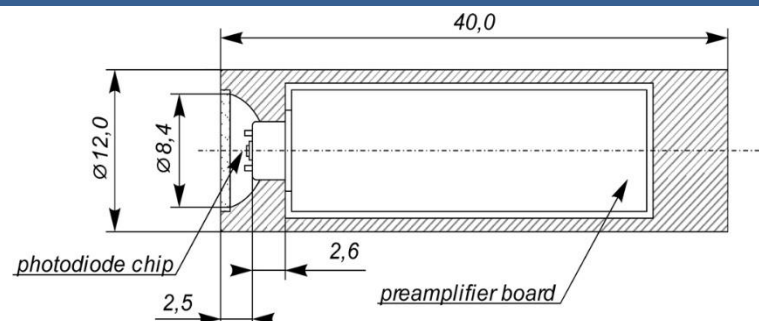

All Dimensions in mm

Power input voltage: +5 V, stabilized

Connections:

The output of PD with a built-in preamplifier has four wires:

- "+" power input (to the "+5V" of the power output terminal block of the synchronous detector);
- "ground" power input (to the "0V" of the power output terminal block of the synchronous detector);
- "ground" output photodiode signal (to the "0V" of the signal input terminal block of the synchronous detector);
- "+" output photodiode signal (to the "IN" of the signal input terminal block of the synchronous detector).

For the proper connection mind the colors of the wires pointed in the technical data provided with the photodiode.



Precautions

Soldering:

- Do avoid overheating of the PD
- Do avoid electrostatic discharge (ESD)
- Do avoid mechanical stress, shock, and vibration
- Do only use non-corrosive flux
- Do not apply current to the LED until it has cooled down to room temperature after soldering

Static Electricity:

PDs are sensitive to electrostatic discharge (ESD). Precautions against ESD must be taken when handling or operating these PDs. Surge voltage or electrostatic discharge can result in complete failure of the device.



© All Rights Reserved

The above specifications are for reference purpose only and subjected to change without prior notice