

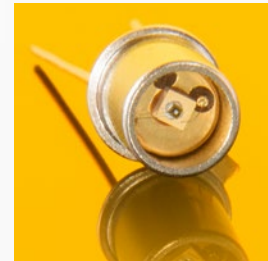

## SIC01S-18

- Broadband UVA+UVB+UVC SiC photodiode
- PTB tested high chip stability
- Active Area: 0.06 mm<sup>2</sup>
- TO18 hermetically sealed metal housing
- 10mW/cm<sup>2</sup> → photocurrent of ~645nA



### Description

SiC provides the unique property of extreme radiation hardness, near-perfect visible blindness, low dark current, high speed and low noise. These features make SiC the best available material for visible blind semiconductor UV detectors. The SiC detectors can be permanently operated at up to 170°C (338°F). The temperature coefficient of signal (responsivity) is also low, <-0.1%/K. Because of the low noise (dark current, in the fA range), very low UV radiation intensities can be measured reliably. Please note that this device needs an appropriate amplifier (see circuit on following page). SiC photodiodes are available as unfiltered broadband devices or with optical filters providing UV-A, UV-B, or UV-C-only sensitivity, or erythemal action curve compliance.

### Maximum Ratings (T = 25°C)

Parameter	Symbol	Values		Unit
		Min.	Max.	
Reverse Voltage	U <sub>R</sub>	+20		V
Operating Temperature	T <sub>opr</sub>	-55	+170	°C
Storage Temperature	T <sub>stg</sub>	-55	+170	°C
Soldering Temperature (max. 3s)	T <sub>sol</sub>		+260	°C

### General Characteristics (T = 25°C)

Parameter	Symbol	Values			Unit
		Min.*	Typ.*	Max.*	
Active Area	A		0.06		mm <sup>2</sup>
Dark current (1V reverse bias)	I <sub>d</sub>		0.2		fA
Capacitance	C		15		pF
Short circuit (10mW/cm <sup>2</sup> at peak)	I <sub>D</sub>		645		nA
Temperature coefficient	T <sub>C</sub>			-0.1	%/K

### Spectral Characteristics (T = 25°C)

Parameter	Symbol	Values			Unit
		Min.*	Typ.*	Max.*	
Max. spectral responsivity	S <sub>max</sub>	0.085		0.130	AW <sup>-1</sup>
Wavelength of max. spectral resp.	λ <sub>max</sub>		280		nm
Responsivity range (S=0.1*S <sub>max</sub> )	-	220		360	nm
Visible blindness (S <sub>max</sub> / S <sub>&gt;405nm</sub> )	VB		10 <sup>10</sup>		-



## Performance Characteristics

Normalized Spectral Responsivity [a.u.]

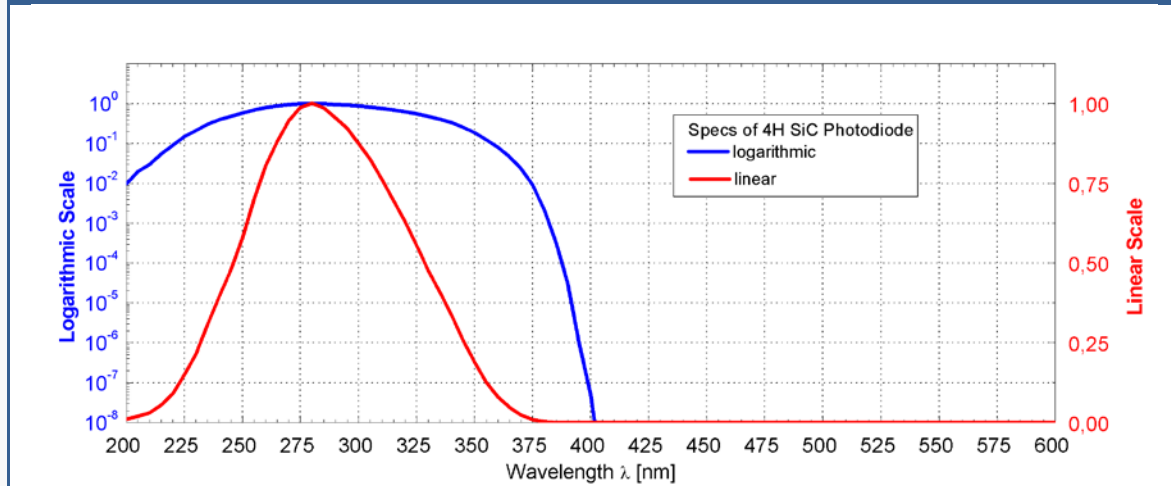

Viewing Angle

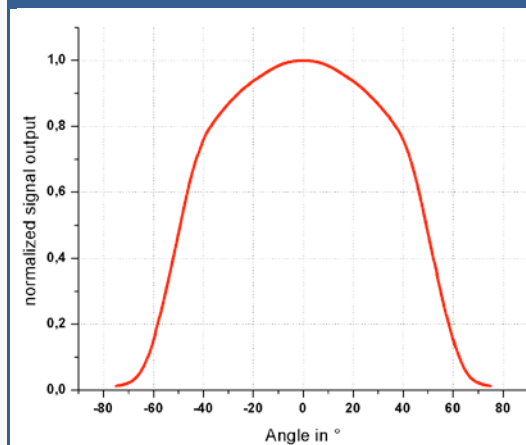

### Measurement Setup

lamp aperture diameter: 10 mm  
distance lamp aperture to second aperture: 17 mm  
second aperture diameter: 10 mm  
distance second aperture to detector: 93 mm

pivot level = top surface of the photodiode window

## Product Portfolio

We offer the following selection of UV Photodiodes:

Option	UV sensitivity	Detector area	Max. spectral responsivity	
			min.	max.
SIC01S-18	UV broadband	0.06 mm <sup>2</sup>	0.085 AW <sup>-1</sup>	0.13 AW <sup>-1</sup>
SIC01S-C18	UVC	0.06 mm <sup>2</sup>	0.066 AW <sup>-1</sup>	0.10 AW <sup>-1</sup>
SIC01S-C5	UVC	0.06 mm <sup>2</sup>	0.066 AW <sup>-1</sup>	0.10 AW <sup>-1</sup>
SIC01S-18ISO90	UV broadband	0.06 mm <sup>2</sup>	0.085 AW <sup>-1</sup>	0.13 AW <sup>-1</sup>
SIC01M-18	UV broadband	0.2 mm <sup>2</sup>	0.085 AW <sup>-1</sup>	0.13 AW <sup>-1</sup>
SIC01M-5Lens	UV broadband	0.2 mm <sup>2</sup>	0.085 AW <sup>-1</sup>	0.13 AW <sup>-1</sup>
SIC01M-C5	UVC	0.2 mm <sup>2</sup>	0.066 AW <sup>-1</sup>	0.10 AW <sup>-1</sup>
SIC01L-18	UV broadband	1.0 mm <sup>2</sup>	0.085 AW <sup>-1</sup>	0.13 AW <sup>-1</sup>
SIC01L-5	UV broadband	1.0 mm <sup>2</sup>	0.085 AW <sup>-1</sup>	0.13 AW <sup>-1</sup>
SIC01L-C5	UVC	1.0 mm <sup>2</sup>	0.066 AW <sup>-1</sup>	0.10 AW <sup>-1</sup>
SIC01XL-5	UV broadband	4.0 mm <sup>2</sup>	0.085 AW <sup>-1</sup>	0.13 AW <sup>-1</sup>

Amplified photodiodes (*TIAMO series*) are also available.



## Outline Dimensions

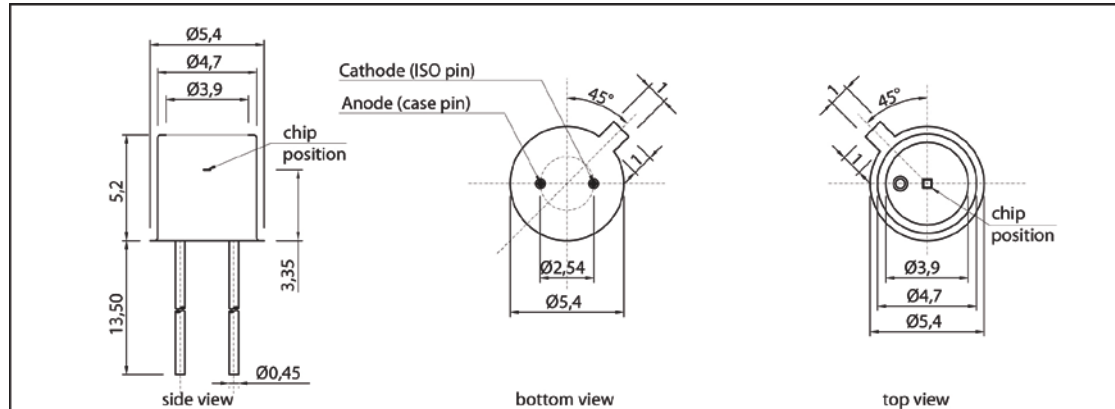

All dimensions in mm

## Circuit

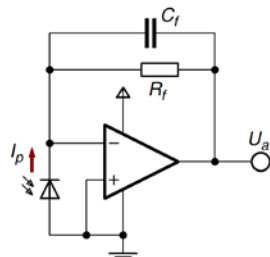

Calculations and Limits:

$$U_a = I_p \cdot R_f = 0 \dots \sim V_{cc}$$

$U_{a,max}$  depends on load and amplifier type

$$R_f = 10 k\Omega \dots \sim 10 G\Omega, C_f \geq 3 pF$$

Recommendation:  $R_f \cdot C_f \geq 10^{-3} s$

$$I_{p,max} = U_{a,max} \div R_f$$

$$Bandwidth = DC \dots \frac{1}{2\pi \cdot R_f \cdot C_f}$$

Example:

$$I_p = 20 nA, R_f = 100 M\Omega, C_f = 100 pF$$

$$U_a = 20 \cdot 10^{-9} A \cdot 100 \cdot 10^6 \Omega = 2 V$$

## Application Note

For correct reading of the photodiode the current (and NOT the voltage) must be analyzed. This requires a short circuiting of the photodiode. Usual approaches are using a Picoamperemeter or a transimpedance amplifier circuit as shown above.

To make the photodiode running reliably, particularly in harsh environment, EMC compatibility and protection against dust, water, and mechanical influences is required. Below listed modules base on a SiC photodiode and guarantee this protection and safety.

**UVTIAMO:** SiC photodiodes with **integrated amplifier** (0-5V output), available for power intensities ranging from  $1.8 pW/cm^2$  to  $18 W/cm^2$  for UV broadband, UVA, UVB, UVC or Erythema (UV-Index) measurements. **No additional amplifier needed, direct connection to voltmeter, controller, etc.**

**UV-probe:** SiC based sensor modules in **customizable industry grade housings** (e.g. cosine response, water pressure proof, sapphire windows) and **different electronic output configurations** (voltage, current, USB, Can) to choose from.

→ Ask us for further details!